

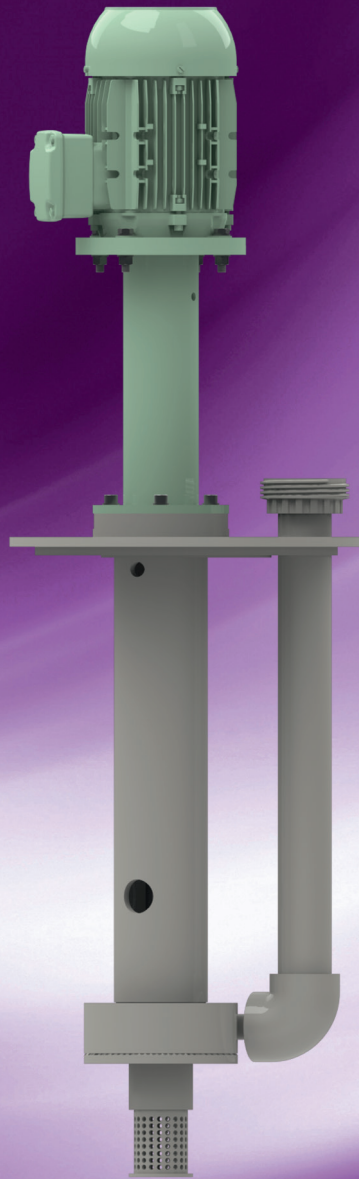

ARBO
THERMOPLASTIC
PUMPS
FILTERS



MODEL DO-L | SEAL-LESS

PG 3.1 IMMERSIBLE CENTRIFUGAL PUMPS



APPLICATIONS

For all transport or circulation duties of corrosive liquids, that may contain even high amount of particles or sludge with medium viscosity. This series of pumps is equipped with a state of the art semi-open impeller that is fixed onto the shaft independent from the direction of rotation.

MATERIALS

Standard is the material PPH that covers a very wide range of duties.

For highly abrasive liquids (high percentage of solids), at special order, impellers of High Modulus Polyethylene are available. For highly corrosive mixtures of acids at higher temperatures even a pump entirely made of virgin PVDF is available..

TECHNICAL DETAILS PUMPS

Design pressure	PN6
Max. system pressure	not applicable; "open system"
Min. flow	DO-70 - 200: 0,25 m ³ /h; DO-300 - 400: 0,5 m ³ /h
Max. flow	40 m ³ /h (60 Hz)
Max. head	34 m (60 Hz)
Max. viscosity	250 mPas
Max. solid size	6 mm

TECHNICAL DETAILS MOTORS

Standard	Three-phase, multivoltage, TEFC
High efficiency	IE2 efficiency level acc. IEC60034-30
Duty	Continuous duty: S1
Multi Voltage	220-240/380-415V 50 Hz // 440-460 V 60 Hz
Protection class	IP55 (IEC 34-5/ NEN-EN 60034-5)
Insulation Class	"F" ($\Delta T=80$ °C);
Max. ambient temperature	Ambient temperature: -30 to 40 °C, at 1000 m.a.s.l.
Max. relative humidity	< 95%

OPTIONAL AVAILABLE

Other voltages	f.i. 480 V/ 3 Ph/ 60 Hz
Other insulation	f.i. Tropicalized
PTC Thermistors	on windings
Thermal or dust protection:	IP56, IP65, IP66, IPW56, IPW65 or IPW66

CONSTRUCTION

MATERIALS	ABBREVIATION	T MIN. °C	T MAX. °C
Polypropylene	PP	0	80
High Modulus Polyethylene	HMPE	-50	80
Polyvinylidenfluoride	PVDF	-30	120
Conductive plastics for ATEX-zones	PP/PVDF/PE-EL		

ORDERING CODE (P.I.C.)

PUMP			VENTILATION CHAMBER	BEARING HOUSING	MATERIALS			CONNECTION	MOTOR					
Type	Housing size	Impeller type/ shaft length	Construction type	Construction type	Wetted parts	Impeller if different	Gaskets	Discharge (d)	Pole	Power kW	Voltage	Phase	Frequency	Atex
DO	70	TS	VDS	L	PP	PVDF	E	R	2	0,55, 0,75	2	1	5	EX
	90				PVC	HMPE	V		4	1,1, 1,5	3	3	6	
	100				PVDF		T			2,2, 3,0	4			
	200									4,0, 5,5	6			
	300													
	400													

PERFORMANCE CURVES DO-L 70-90

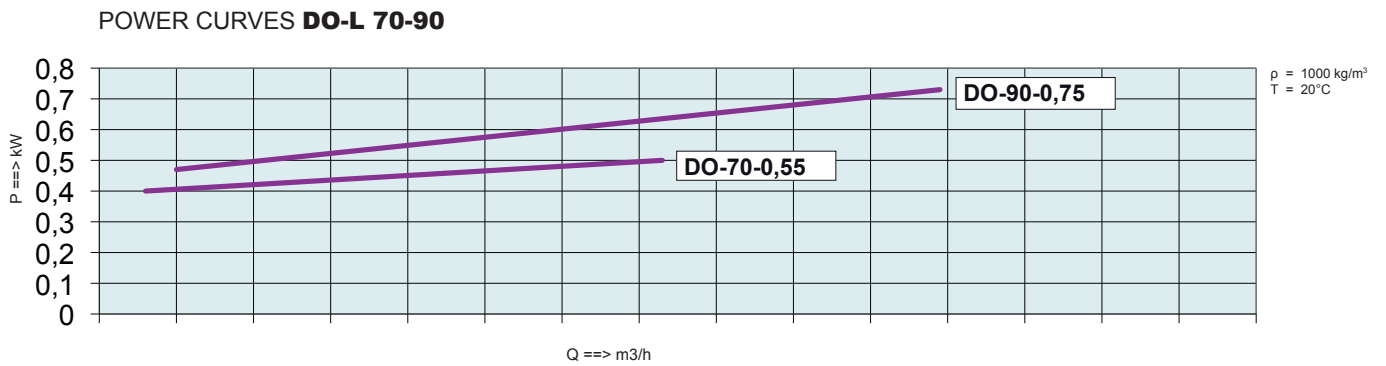
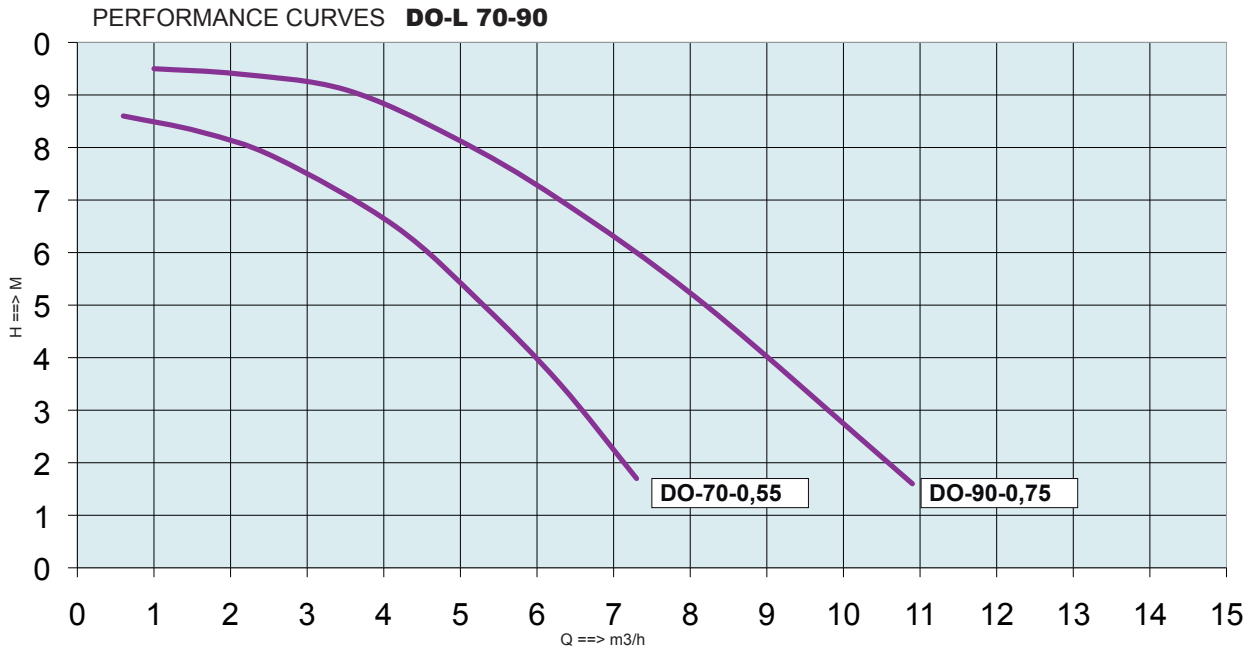

PERFORMANCE CURVES DO-L 100-300

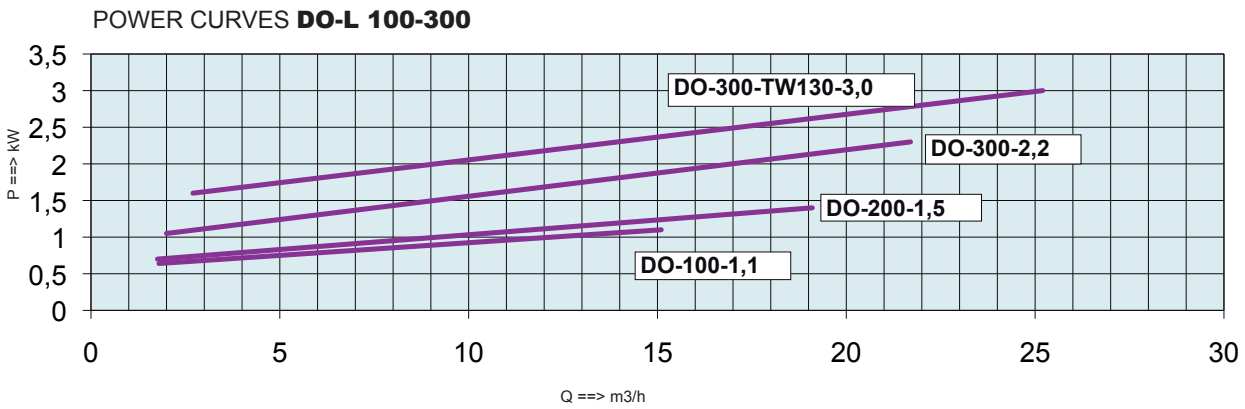
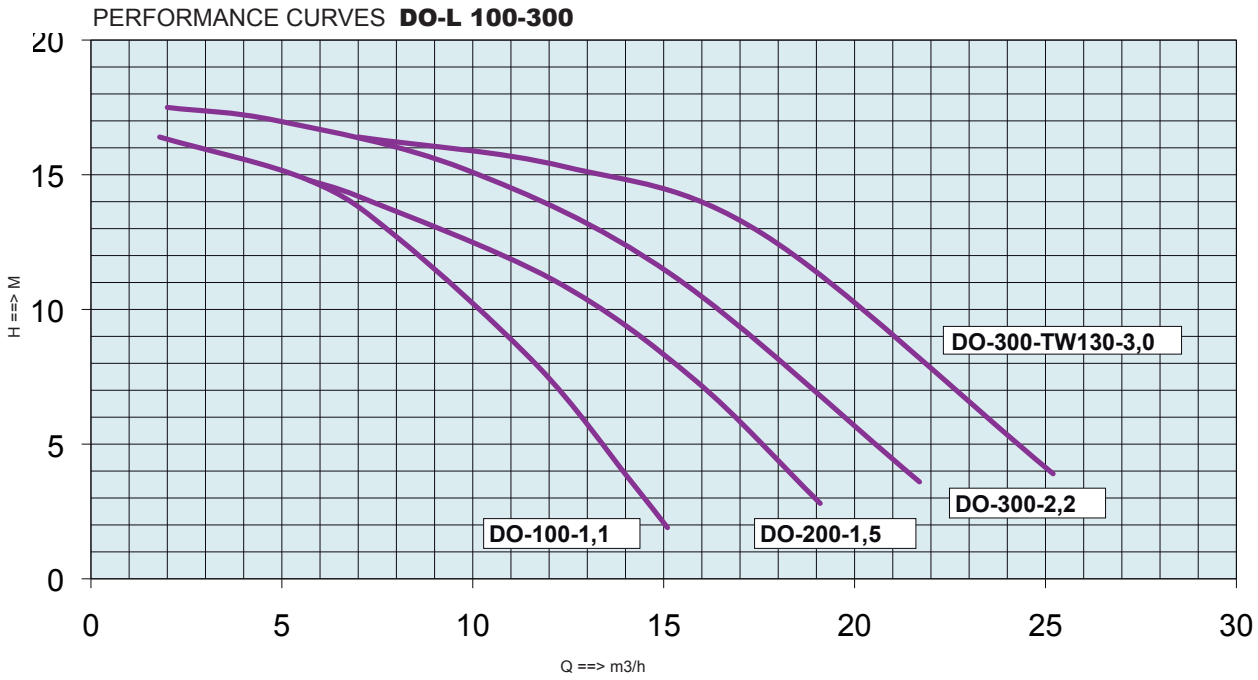

PERFORMANCE CURVES DO-L 400

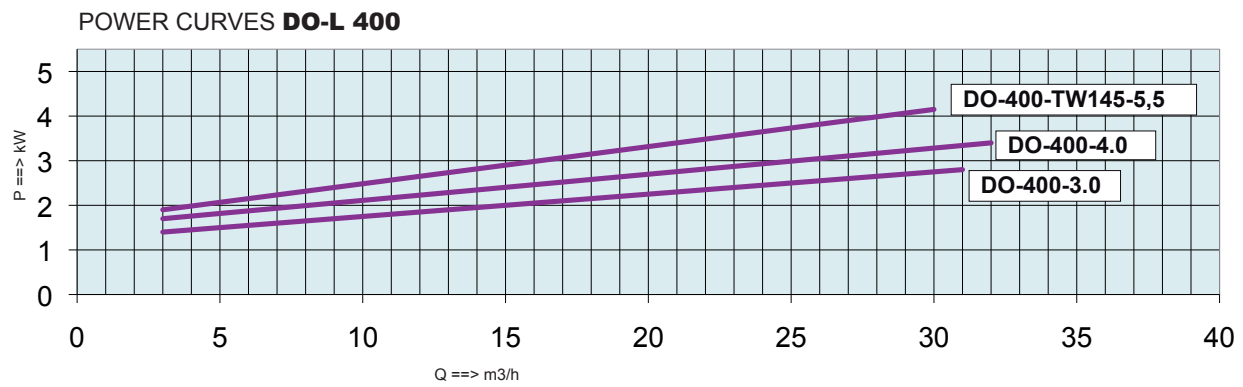

DIMENSIONS / WEIGHTS DO-L 70-300

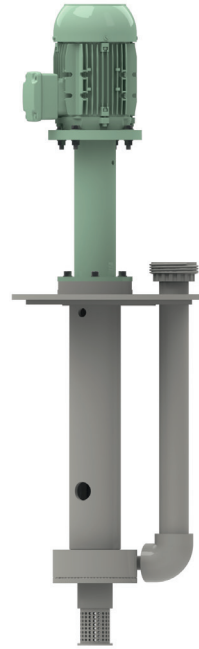
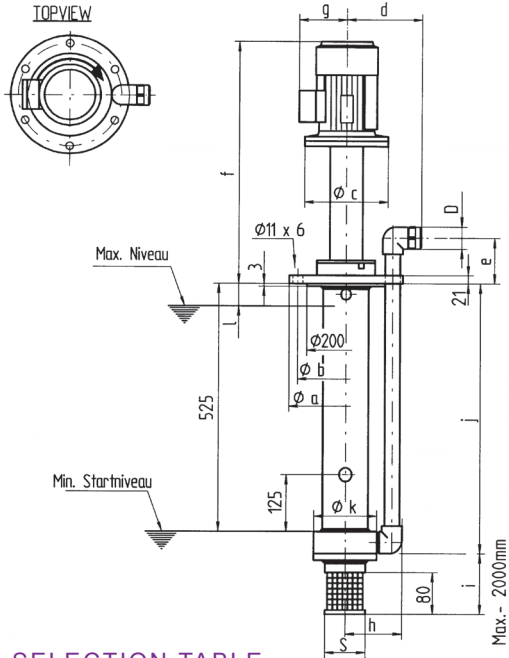

SELECTION TABLE

MODEL DO	IMPELLER SIZE Ø MM		PUMP PERFORMANCE			MOTOR POWER KW	I NOM.
			Q. MAX	H. MAX	SG. MAX	2850 MIN-1	400V/3PH/ 50HZ
TYPE	50 Hz	60 Hz	M3/u	M	(ρ) kg/m3	50 Hz	A
70	95	80	7,5	8,5	1200	0,55	1,45
90	100	90	11	9,5	1150	0,75	1,80
100	120	100	15	16	1100	1,1	2,30
200	120	100	19	16	1150	1,5	3,14
300	130	100	22	17	1100	2,2	4,58
300	130TW	100TW	25	17	1100	3,0	5,92

DO	MOTOR	THREADED** X DN		DIMENSIONS (MM)											WEIGHT	PALLET	
TYPE	IEC	D	S	a	b	C	d	e	f	g	h	i*	j	k	l	ca. Kg	CM
70	71M	1 1/2"-25	75	280	252	200	187	70	576	102	135	100	583	160	100	38	160x53x53
90	80M	2"- 32	75	300	252	200	203	80	607	118	150	100	583	160	100	40	160x53x53
100	80M	2"- 33	75	280	252	200	188	70	578	118	145	129	586	160	50	44	160x53x53
200	90S	2 1/4"-40	75	300	252	200	220	80	592	124	153	129	586	160	50	50	160x53x53
300	90L	2 1/4"-40	75	335	252	200	289	90	614	124	170	145	586	160	50	55	160x53x53
300	100L	2 1/4"-40	75	335	252	250	289	90	717	141	170	145	586	160	50	90	160x80x53

* extension to max. 2000 mm total immersible length

** male straight pipe thread

DIMENSIONS / WEIGHTS DO-L 400

SELECTION TABLE

MODEL DO	IMPELLER SIZE Ø MM		PUMP PERFORMANCE			MOTOR POWER KW	I NOM.
			Q. MAX	H. MAX	SG. MAX	2850 MIN-1	400V/3PH/ 50HZ
TYPE	50 Hz	60 Hz	M3/u	M	(ρ) kg/m3	50 Hz	A
400	125	105	31	18	1100	3,0	5,92
400	125	105	31	18	1400	4,0	7,72
400	140	115	34	23	1350	4,0	7,72
400	140	115	34	23	1700	5,5	10,50
400	145TW	120TW	30	27	1400	5,5	10,50

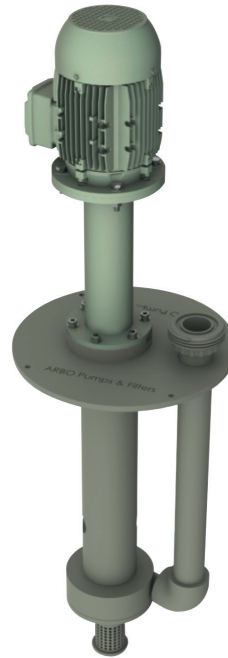
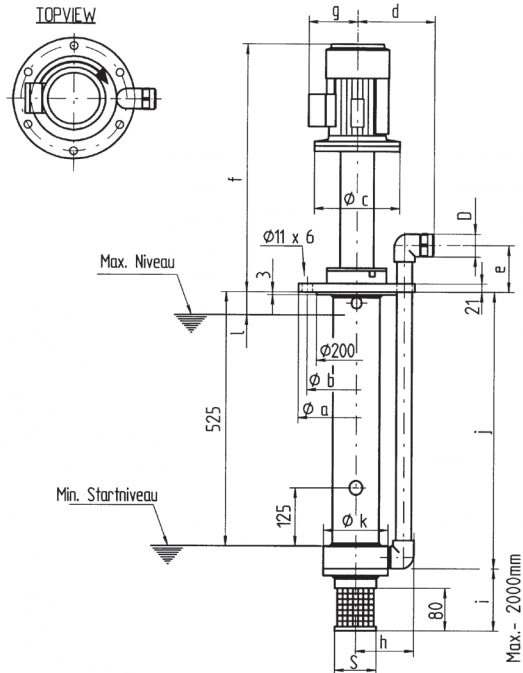
DIMENSIONS / WEIGHTS DO-L 400

DO	MOTOR	THREADED** X DN	DIMENSIONS (MM)													WEIGHT	PALLET
TYPE	IEC	D	S	a	b	C	d	e	f	g	h	i*	j	k	l	ca. Kg	CM
400	100L	2 3/4"- 50	75	335	308	250	273	110	717	141	205	145	586	180	50	100	160x80x53
400	112M	2 3/4"- 50	75	335	308	250	273	110	760	141	205	145	586	180	50	105	160x80x53
400	112M	2 3/4"- 50	75	335	308	250	203	110	760	202	205	145	586	180	50	110	160x80x53

* extension to max. 2000 mm total immersible length

** male straight pipe thread

FLANGE DIMENSIONS ACCORDING DIN2501 PN10

DN	G"	D	PDC	d4	b	d2xn
15	1"	95	65	3	19	14x4
20	1 1/4"	105	75	3	19	
25	1 1/2"	115	85	3	19	
32	2"	140	100	3	19	
40	2 1/4"	150	110	3	20	18x4
50	2 3/4"	165	125	3	24	
65	2 3/4"	185	145	3	24	

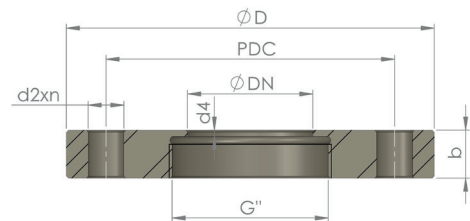

MOTOR	2900 MIN-1	WEIGHT	* IN	D	E	LE
IEC	kW	+/- KG	A	(mm)	(mm)	(mm)
71M	0,55	8,3	1,45	Ø14	30	260
80M	0,75	10	1,8	Ø19	40	280
80M	1,1	14	2,3	Ø19	40	280
90S	1,5	17,5	3,14	Ø24	50	295
90L	2,2	21	4,58	Ø24	50	320
100L	3	28	5,92	Ø28	60	360
112M	4	38	7,72	Ø28	60	405
112M	5,5	42	10,5	Ø28	60	405

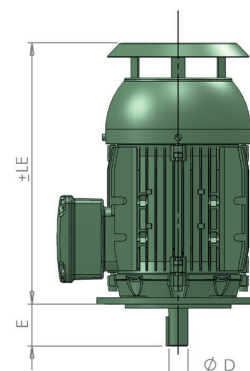

PG 3.1 IMMERSIBLE CENTRIFUGAL PUMPS

SEAL - L E S S



COMPACT CONSTRUCTION

UP TO 300 M3/H

In this series the pump is directly mounted onto the motor flange by means of a plastic bracket.



LONG COUPLED CONSTRUCTION

UP TO 40 M3/H

A number of models are available with bearing housing between the pump and the electric motor. Thanks to this construction it is possible to work without a foot bearing and makes it possible to mount longer pump shafts. This results in a lower minimum starting level in the tank.



MODEL BB:

Every ARBO immersible pump can be supplied in an "Out of tank" construction. The main advantage is the dry erection of the pump in situations where there is insufficient mounting space in the tank.



ARBO
POMPEN EN FILTERS B.V.

Leemdijk 2
9422 CL SMILDE
THE NETHERLANDS

T : +31 (0) 592 430 310

E : info@arbo-pumps.com
I : www.arbo-pumps.com

DISTRIBUTED BY: