



ARBO
THERMOPLASTIC
PUMPS
FILTERS



MODEL HD-DO | SEAL-LESS

PG 3.5 IMMERSIBLE CENTRIFUGAL PUMPS

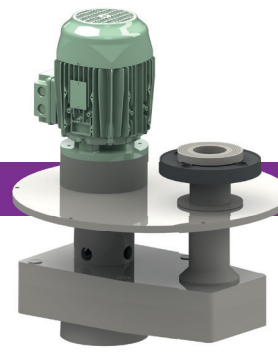

APPLICATIONS

For all transport or circulation duties of corrosive liquids, that may contain even high amount of particles or sludge with medium viscosity.

This series of pumps is equipped with a state of the art semi-open impeller that is fixed onto the shaft independent from the direction of rotation.

MATERIALS

Standard is the material PP that covers a very wide range of duties.

For highly abrasive liquids (high percentage of solids), at special order, impellers or housing parts of High Modulus Polyethylene (**HMPE**) are available.

For highly corrosive mixtures of acids at higher temperatures even a pump housing entirely made of virgin **PVDF** is available.

TECHNICAL DETAILS PUMPS

Design pressure	PN6 - PN10 speed related
Max. system pressure	not applicable; "open system"
Min. flow	1 m ³ /h
Max. flow	300 m ³ /h
Max. head	80 m
Max. viscosity	250 mPas
Max. solid size	3-5 mm depending on type
Max. solid size	3 mm

TECHNICAL DETAILS MOTORS

Standard	Three-phase, multivoltage, TEFC
Efficiency level < 7,5 kW	IE2 acc. IEC60034-30
Efficiency level > 5,5 kW	IE3 acc. IEC60034-30
Duty	Continuous duty: S1
Multi Voltage	220-240/380-415V 50 Hz // 440-460 V 60 Hz
Protection class	IP55 (IEC 34-5/ NEN-EN 60034-5)
Insulation Class	"F" ($\Delta T=80^{\circ}C$);
Max. ambient temperature	-30 to 40°C, at 1000 m.a.s.l.
Max. relative humidity	< 95%

OPTIONAL AVAILABLE

Other voltages	f.i. 480 V/ 3 Ph/ 60 Hz
Other insulation	f.i. Tropicalized
PTC Thermistors	on windings
Thermal or dust protection:	IP56, IP65, IP66, IPW56, IPW65 or IPW66

MATERIALS OF CONSTRUCTION	ABBREVIATION	T MIN. °C	T MAX. °C
Polypropylene	PP	0	80
High Modulus Polyethylene *	HMPE	-50	80
Polyvinylidene fluoride	PVDF	-30	120
Polytetrafluorethylene *	PTFE	-30	140

* for pump housing and/or impeller only

MATERIALS OF ELASTOMERS	ABBREVIATION	T MIN. °C	T MAX. °C
EPDM	E	-40	150
Viton	V	-25	220
Viton/PTFE encapsulated	T	-190	260

MATERIALS OF CONNECTIONS	ABBREVIATION
DIN2501 PN10 Flange	F

ORDERING CODE (P.I.C.)

PUMP				MATERIALS				CONNECTION		MOTOR					
Model	Discharge size (D)	Housing size	Shaft construction	Wetted parts	Impeller if different	Gas seal	Gaskets	Discharge (d)	Pole	Power kW	Voltage	Phase	Frequency	Atex	
DO	40	160	DW	PP	PVDF	GD	E	U	2	0,75, 1,1	2	3	5	EX	
	50	200		PVDF	HMPE		V	F	4	1,5, 2,2	3				6
	65	200-SL	250-SL	HMPE			T	BB	6	3,0, 4,0	4				
	80	250								5,5, 7,5	6				
	100	250-SL									11, 15				
	150-80										18,5, 22				
150-125										30					

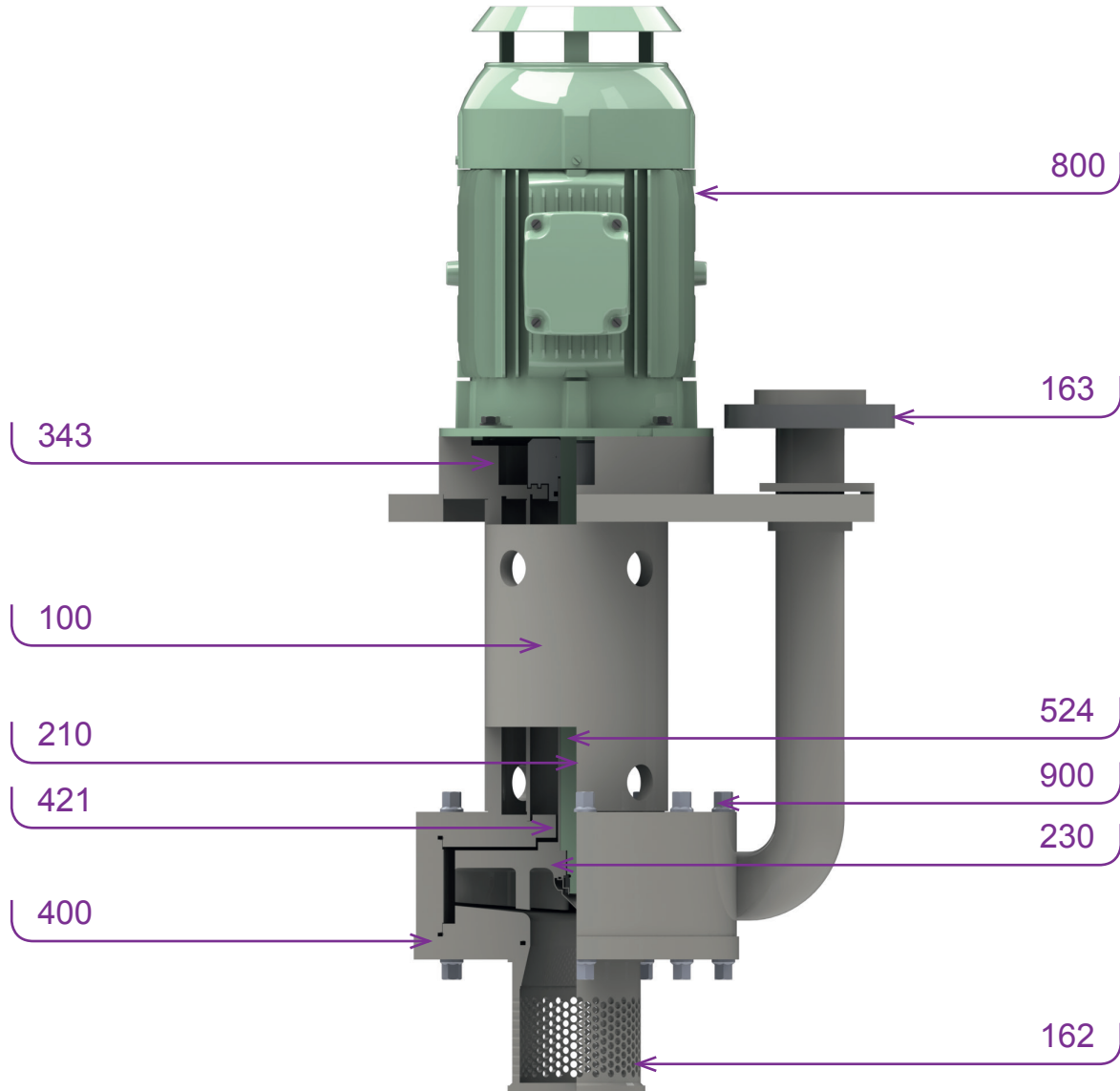

POS.	DESCRIPTION	STANDARD	ALTERNATIVES		
			HMPE	PVDF	PTFE
100	Housing parts	PP	HMPE	PVDF	PTFE
162	Suction adaptor	PP	Extended suction pipe with or without strainer		
163	Discharge adapter	PP	DIN of ANSI flange	Threaded end	
210	Pump shaft	SS	Titanium		
230	Impeller (semi-open)	PP	HMPE	PVDF	
343	Pump bracket	PP			
400	Gaskets	EPDM	VITON	PTFE encapsulated	
421	Mechanical seal	NONE; liquid seal			
423	Fume seal	Labyrinth	Gas seal		
524	Shaft protecting sleeve	PP	PVDF		
800	Motor	2, 4 or 6-pole			
900	Fasteners in liquid zone	Vinylester	RVS-316	PEEK	
	other fasteners	SS-316	Titanium	Hasteloy C	

FEATURES

Standard provided with DIN2501 PN10 flange. Options:

- ANSI flanges
- Model BB for out of tank

Labyrinth prevents fumes from the pump to exit into the atmosphere when the pump is operating:

- less motor corrosion
- better atmosphere around the pump

Optional:

unique gas seal available for extremely corrosive or dangerous liquids

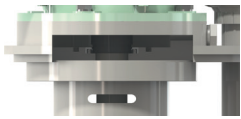

Motor optimized to run under tough conditions.

Ventilation chamber protects motor shaft, bearing shields and bearings against corrosive fumes

Semi-open impeller type:

- direction independent fixation
- for transfer and circulation
- increased efficiency = less energy consumption
- special impellers available for low flow – high head applications
- very smooth and quiet
- air free operation, even at very low liquid level
- anti-clogging

Extra heavy duty lock nut for secure impeller fixation.

Solid pump housing. Available in other wear resistant materials.

Screwed suction pipe. Standard with large surface suction strainer. Suction pipe extensions available.

OPTIONS



SUCTION PIPE

ARBO offers suction pipe extension up to a total immersible length of 3 mtr.

Extended suction pipes are split into sections of 1.2 mtr. maximum for easy transport.

It is recommended to support long suction pipes to the sump wall, however these supports need some flexibility and should not cause vibration.

FOOTVALVE (FOR CLEAN SOLUTIONS ONLY)

If starting at any level is requested, ARBO offers a very reliable corrosion resistant foot valve to maintain the liquid level inside the pump housing.

Filled once, the pump is able to start again even though the liquid level in the sump is below the impeller housing.

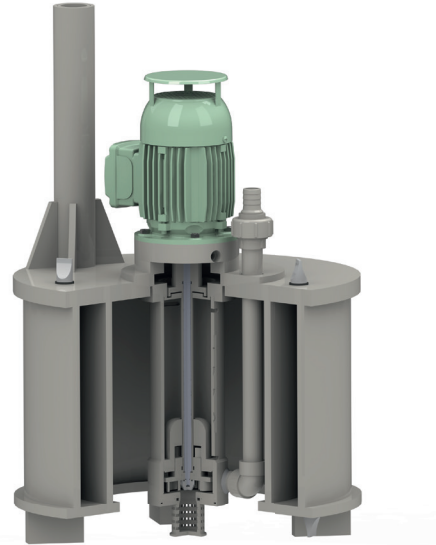

Model D0-D Float mounted sump pump

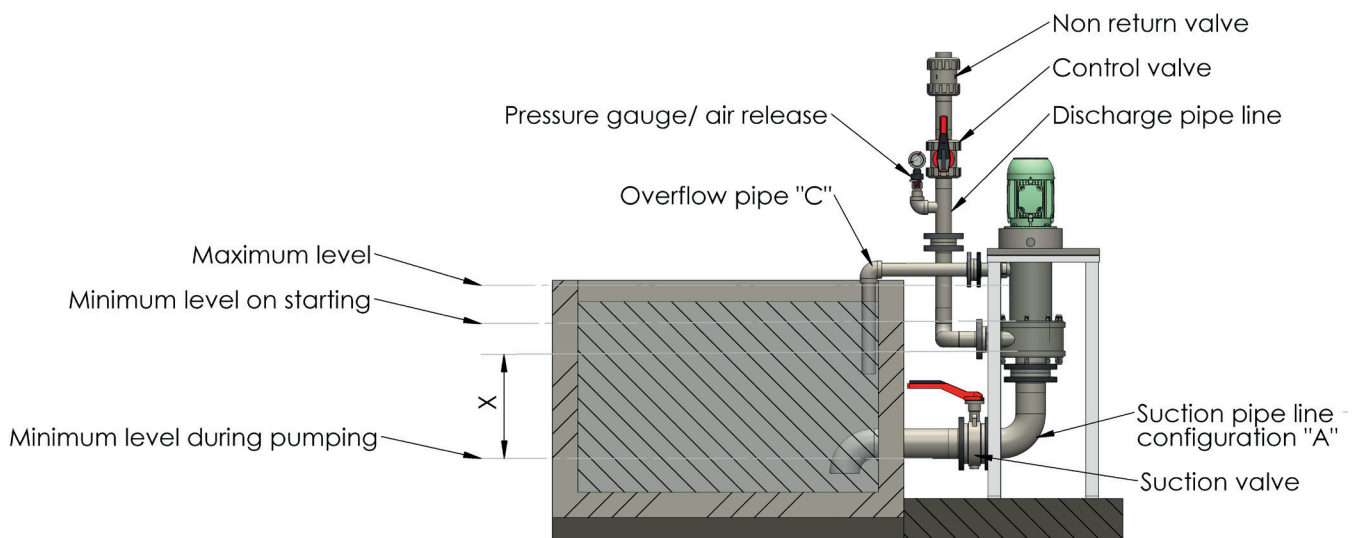

Model BB with full options

DIMENSIONS / WEIGHTS HD-DO 160

HD-DO HOUSING 160	DIMENSIONS / WEIGHTS PUMP WITHOUT MOTOR INCL. STANDARD SUCTION PIPE(MM) *																					
TYPE	a*	c	c1	g	h1	h2	h3	h	i	m	n1	n4	n5	n6	DNd	d2xn	PDC	DNs	s	f	p	LE
32-160	145	224	387	191	205	255	460	145	50	310	530	450	225	30	32	18x4	100	80	100	458	8	549
40-160	145	224	392	161	205	255	460	145	50	310	530	450	225	30	40	18x4	110	80	100	458	8	508
40-160	145	224	392	191	205	255	460	145	50	310	530	450	225	30	40	18x4	110	80	100	458	8	549
40-160	145	224	392	223	205	255	460	145	50	310	530	450	225	30	40	18x4	110	80	100	458	8	628
50-160	145	224	399	191	205	255	460	145	50	310	530	450	225	30	50	18x4	125	80	100	458	8	549
50-160	145	224	399	223	205	255	460	250	50	310	530	450	225	30	50	18x4	125	80	100	458	8	628
65-160	136	240	450	161	205	255	460	145	100	335	530	450	225	30	65	18x4	145	125	150	478	8	508
65-160	136	240	450	191	205	255	460	145	100	335	530	450	225	30	65	18x4	145	125	150	478	8	549
65-160	136	240	450	223	205	255	460	250	100	335	530	450	225	30	65	18x4	145	125	150	478	8	628
100-160	136	240	450	161	205	255	460	145	100	335	530	450	225	30	100	18x8	180	125	150	478	8	508
100-160	136	240	450	191	205	255	460	145	100	335	530	450	225	30	100	18x8	180	125	150	478	8	549

* extension up to max. 3000 mm total immersible length

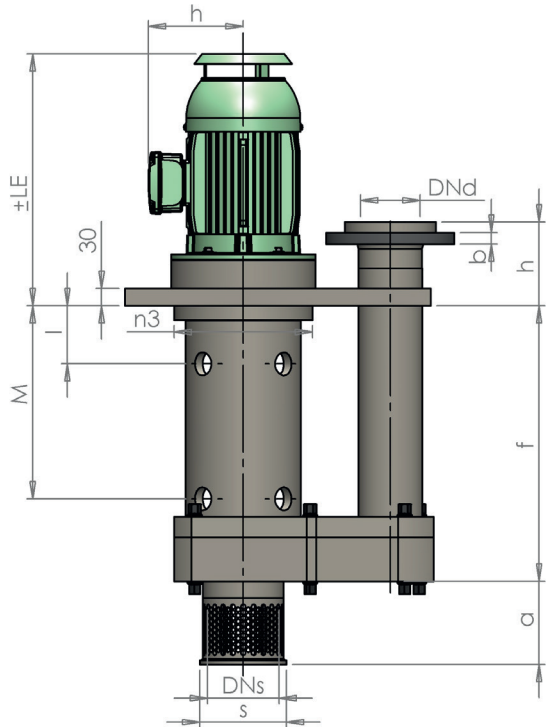
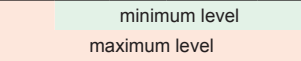

HD-DO HOUSING 160	MOTOR FRAME	KG PUMP WITHOUT MOTOR	
		PP	PVDF
TYPE	IEC		
32-160	132	32	58
40-160	100-112	33	59
40-160	132	33	59
40-160	160	34	61
50-160	132	34	61
50-160	160	35	63
65-160	100-112	35	63
65-160	132	36	65
65-160	160	37	67
100-160	100-112	36	65
100-160	132	37	67

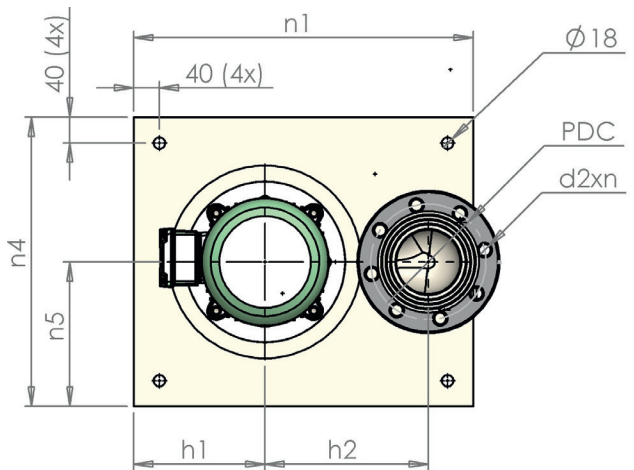
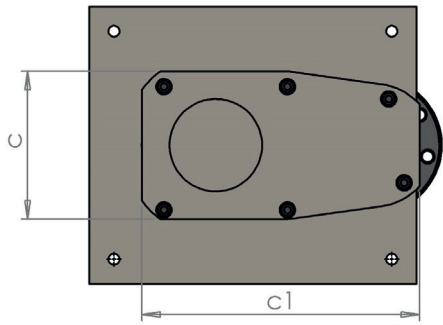

DIMENSIONS / WEIGHTS HD-DO 200 AND 200SL

HD-DO HOUSING 200	DIMENSIONS / WEIGHTS PUMP WITHOUT MOTOR INCL. STANDARD SUCTION PIPE(MM) *																					
TYPE	a*	c	c1	g	h1	h2	h3	h	i	m	n1	n4	n5	n6	DNd	d2xn	PDC	DNs	s	f	p	LE
40-200	145	328	444	161	205	255	460	145	50	310	530	450	225	30	40	18x4	110	80	100	478	8	508
40-200	145	328	444	191	205	255	460	145	50	310	530	450	225	30	40	18x4	110	80	100	478	8	549
40-200	145	328	444	223	205	255	460	250	50	310	530	450	225	30	40	18x4	110	80	100	478	8	628
50-200	145	328	451	161	205	255	460	145	50	310	530	450	225	30	50	18x4	125	80	100	478	8	508
50-200-DW	145	328	451	191	205	255	460	145	50	310	530	450	225	30	50	18x4	125	80	100	478	8	549
50-200-DW	145	328	451	223	205	255	460	250	50	310	530	450	225	30	50	18x4	125	80	100	478	8	628
65-200	145	328	457	161	205	255	460	145	50	310	530	450	225	30	65	18x4	145	125	150	478	8	508
65-200-DW	145	328	457	191	205	255	460	145	50	310	530	450	225	30	65	18x4	145	125	150	478	8	519
65-200-DW	145	328	457	223	205	255	460	250	50	310	530	450	225	30	65	18x4	145	125	150	478	8	628
100-200-DW	145	328	474	191	205	255	460	250	50	310	530	450	225	30	100	18x8	180	125	150	478	8	519
100-200-DW	145	328	474	223	205	255	460	250	50	310	530	450	225	30	100	18x8	180	125	150	478	8	826

* extension up to max. 3000 mm total immersible length

minimum level

maximum level

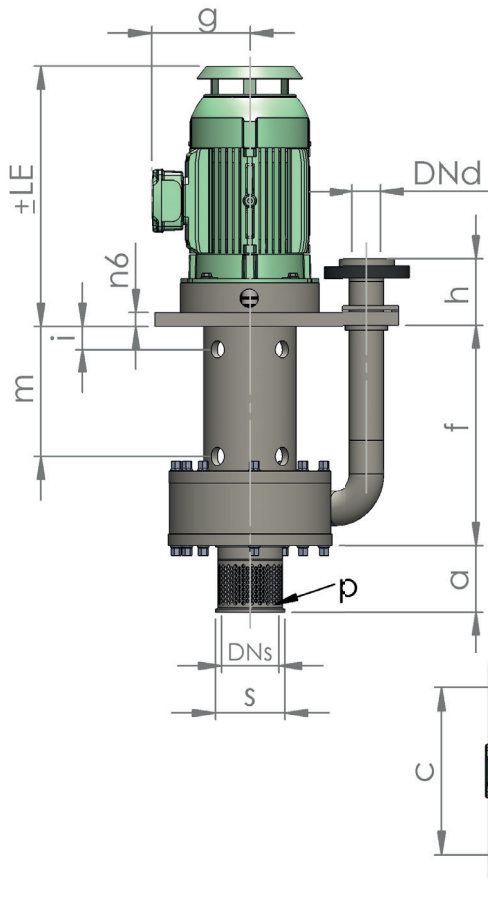

HD-DO HOUSING 200	MOTOR FRAME	KG PUMP WITHOUT MOTOR	
		IEC	PVDF
40-200	100-112	35	63
40-200	132	36	65
40-200	160	37	67
50-200	100-112	42	76
50-200-DW	132	40	72
50-200-DW	160	41	74
65-200	100-112	43	77
65-200-DW	132	41	74
65-200-DW	160	42	76
100-200-DW	132	50	90
100-200-DW	160	51	92

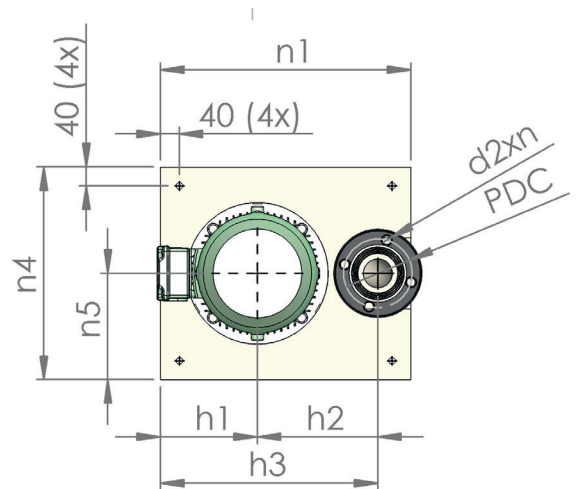

HD-DO HOUSING 200-SL	DIMENSIONS / WEIGHTS PUMP WITHOUT MOTOR INCL. STANDARD SUCTION PIPE(MM) *																					
TYPE	a*	c	c1	g	h1	h2	h3	h	i	m	n1	n4	n5	n6	DNd	d2xn	PDC	DNs	s	f	p	LE
65-200-DW	145	328	457	223	205	255	460	145	50	471	530	450	225	30	65	18x4	145	125	150	632	8	519

* extension up to max. 3000 mm total immersible length

minimum level

maximum level

HD-DO HOUSING 200-SL	MOTOR FRAME	KG PUMP WITHOUT MOTOR	
		IEC	PVDF
65-200-DW	132	55	99

DIMENSIONS / WEIGHTS HD-DO 250 AND 250SL

HD-DO HOUSING 250	DIMENSIONS / WEIGHTS PUMP WITHOUT MOTOR INCL. STANDARD SUCTION PIPE(MM) *																					
TYPE	a*	c	c1	g	h1	h2	h3	h	i	m	n1	n4	n5	n6	DNd	d2xn	PDC	DNs	s	f	p	LE
40-250	145	355	457,5	161	205	255	460	145	50	310	530	450	225	30	40	18x4	110	80	100	478	8	508
40-250	145	355	457,5	191	205	255	460	145	50	310	530	450	225	30	40	18x4	110	80	100	478	8	549
40-250	145	355	457,5	223	205	255	460	250	50	310	530	450	225	30	40	18x4	110	80	100	478	8	658
50-250	145	355	464,5	161	205	255	460	145	50	310	530	450	225	30	50	18x4	125	80	100	478	8	508
50-250	145	355	464,5	191	205	255	460	145	50	310	530	450	225	30	50	18x4	125	80	100	478	8	549
65-250-DW	145	355	470,5	191	205	255	460	145	50	310	530	450	225	30	65	18x4	145	125	150	478	8	519
65-250-DW	145	355	470,5	223	205	255	460	250	50	310	530	450	225	30	65	18x4	145	125	150	478	8	628
100-250-DW	145	355	487,5	191	205	255	460	250	50	310	530	450	225	30	100	18x8	180	125	150	478	8	519
100-250-DW	145	355	487,5	223	205	255	460	728	50	310	530	450	225	30	100	18x8	180	125	150	478	8	826
**150-80-250-DW	145	445	703,5	265	238	421	659	145	40	307	750	600	300	40	125	18x8	210	150	170	478	10	700
**150-125-250-DW	145	445	734	265	238	421	659	145	40	307	750	600	300	40	125	18x8	210	150	170	478	10	700

* extension up to max. 3000 mm total immersible length
 ** no suction pipe extension possible

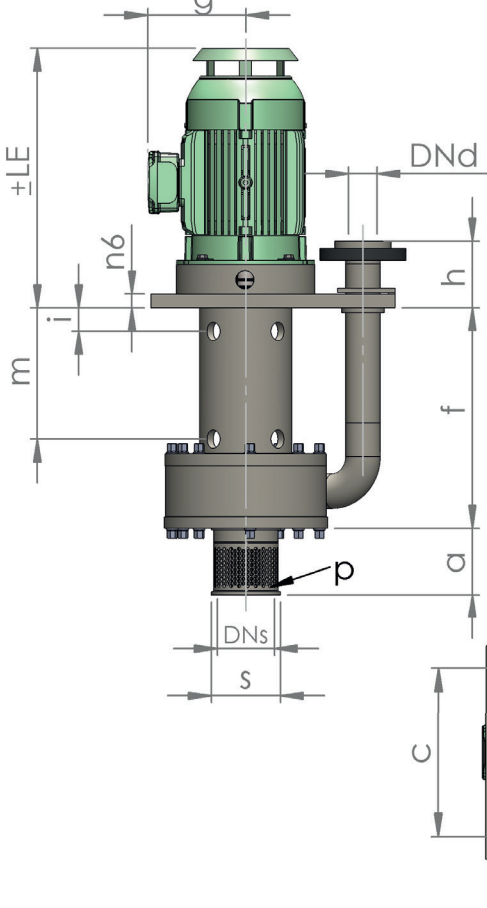
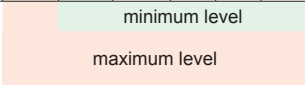

HD-DO HOUSING 250	MOTOR FRAME	KG PUMP WITHOUT MOTOR	
TYPE	IEC	PP	PVDF
40-250	112	36	65
40-250	132	37	67
40-250	160	38	68
50-250	112	43	77
50-250	132	44	79
65-250-DW	132	42	76
65-250-DW	160	43	77
100-250-DW	132	51	92
100-250-DW	160	52	94
**150-80-250-DW	180	70	126
**150-125-250-DW	180	75	135

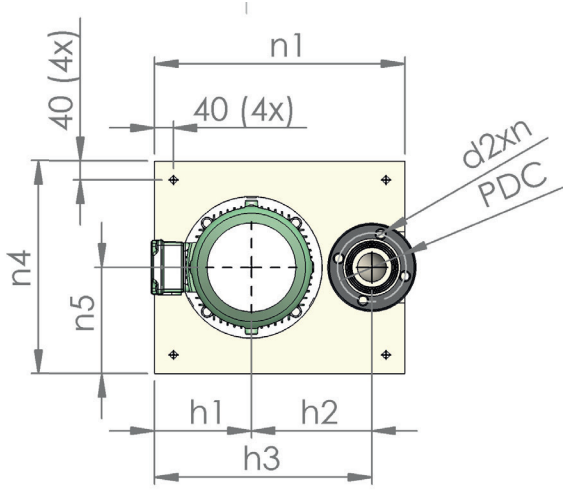

HD-DO HOUSING 250-SL	DIMENSIONS / WEIGHTS PUMP WITHOUT MOTOR INCL. STANDARD SUCTION PIPE(MM) *																					
TYPE	a*	c	c1	g	h1	h2	h3	h	i	m	n1	n4	n5	n6	DNd	d2xn	PDC	DNs	s	f	p	LE
65-250-DW	145	355	470,5	223	205	255	460	145	50	471	530	450	225	30	65	18x4	145	125	150	632	8	519

* extension up to max. 3000 mm total immersible length

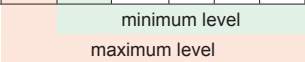

HD-DO HOUSING 250-SL	MOTOR FRAME	KG PUMP WITHOUT MOTOR	
TYPE	IEC	PP	PVDF
65-250-DW	132	56	101

DIMENSIONS / WEIGHTS POS.800 MOTORS

IEC STANDARD

MOTOR	960 min-1	WEIGHT	* I _n	1450 min-1	WEIGHT	* I _n	2900 min-1	GEWICHT	* I _n	D	E	LE
IEC	kW	+/- Kg	A	kW	+/- Kg	A	kW	+/- Kg	A	(mm)	(mm)	(mm)
90L	-	-	-	1,5	22	3,26	2,2	21	4,58	Ø24	50	320
100L	-	-	-	2,2	30,5	4,64	-	-	-	Ø28	60	360
100L	-	-	-	3	33	6,17	3	28	5,92	Ø28	60	360
112M	-	-	-	4	42	8,12	4	38	7,72	Ø28	60	405
112M	-	-	-	-	-	-	5,5	60	10,5	Ø28	60	405
132S	-	-	-	-	-	-	5,5	60	10,6	Ø38	60**	420
132S	-	-	-	5,5	63	10,5	7,5	63	14,1	Ø38	60**	420
132M	-	-	-	7,5	72	14,1	-	-	-	Ø38	60**	455
160M	7,5	113	15	11	105	21,2	11	104	20,4	Ø42	60**	560
160M	-	-	-	-	-	-	15	112	27,6	Ø42	60**	560
160L	11	136	22	15	125	28,7	18,5	124	33,7	Ø42	60**	590

* I_{nominal} at 400 V / 3 Ph / 50 Hz

** shaft stub shortened

DW-MOTORS

MOTOR	1450 min-1	WEIGHT	* I _n	2900 min-1	WEIGHT	* I _n	D	E	LE
IEC	kW	+/- Kg	A	kW	+/- Kg	A	(mm)	(mm)	(mm)
132S-DW	-	-	-	5,5	65	10,6	Ø35	453	420
132S-DW	5,5	65	10,5	7,5	65	14,1	Ø35	453	420
132S-DW-SL	5,5	67	10,5	-	-	-	Ø35	637	455
132M-DW	7,5	74	14,1	-	-	-	Ø35	453	455
132M-DW-SL	7,5	76	14,1	-	-	-	Ø35	637	455
160M-DW	11	107	21,2	-	-	-	Ø35	453	560
160L-DW	15	127	28,7	-	-	-	Ø35	453	590
180M-DW	18,5	170	35,1	22	170	39,1	Ø48	436	610

* I_{nominal} at 400 V / 3 Ph / 50 Hz

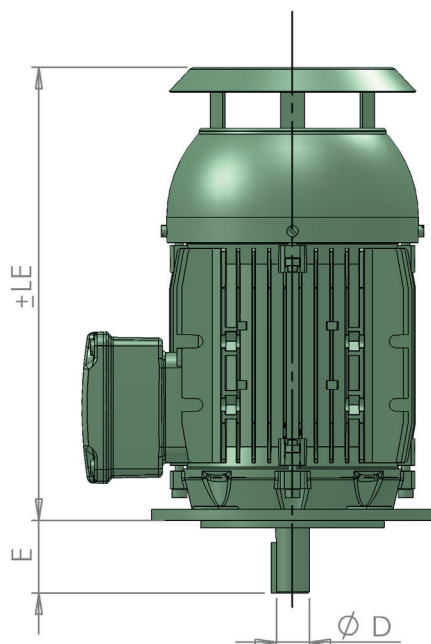

IEC Standard Motor

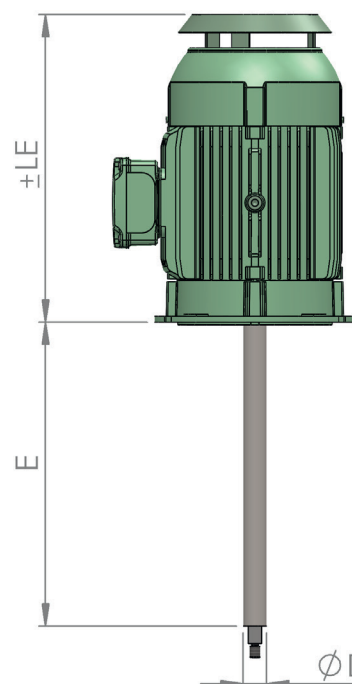

DW Motor

DIMENSIONS / WEIGHTS HD-DO

TYPE	MOTOR FRAME	PALLET SIZE CM			VOLUME	PALLET
		L	W	H		
DO-32-160 - 100-250	160	120	80	60	0,58	23
DO-150-80-250 - 150-125-250	100-112	140*)	100	80	1,12	25
DO-65-200-SL - DO- 100-250-SL	160	140*)	100	80	1,12	25

*) Pallet - without stacking frame

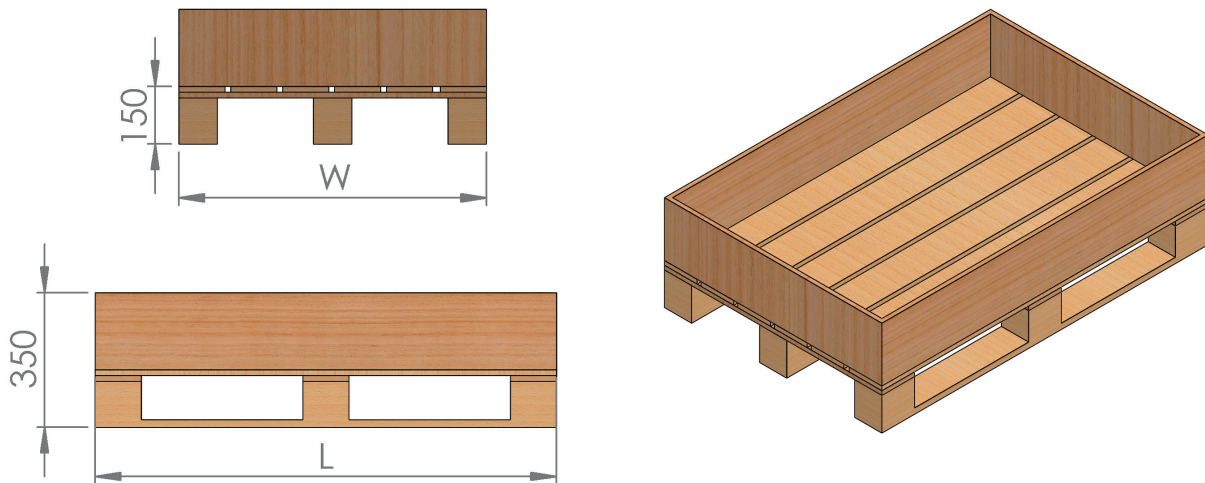

Immersible pumps on scrubbers



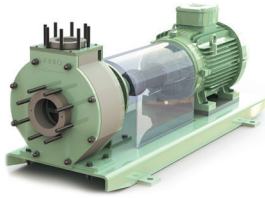

**CENTRIFUGAL PUMPS
WITH MECHANICAL SEAL**
SealPro and HD series
KR (Close) and TK (Long) coupled versions
Single, double and bellow seals
Max. 600 m³/h, max. 90 m

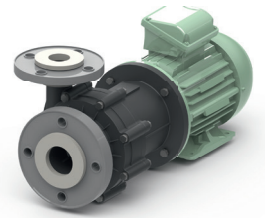

**MAGNETIC DRIVE
CENTRIFUGAL PUMPS**
MagPro series
Max. 60 m³/h, max. 90 m.



**SEALLESS IMMERSIBLE
CENTRIFUGAL PUMPS**
SumPro and HD series
Max. 300 m³/h, max. 90 m



**PUMP PROTECTION
DRY RUNNING PROTECTOR**
Pressure gauges
Priming units
Suction strainers



FILTER CHAMBERS
For cartridges, discs or bag filters.
Capacity to 40 m³/h
Can be combined with any ARBO pump
Filter rates of 0,2 to 1200 micron



OIL SKIMMERS
Capacity 0 - 4 l/h
Length 400 - 3000 mm
Max. 70°C



ARBO PUMPS | FILTERS

Since the foundation in 1954, **ARBO** Pumps | Filters specialized on the design and production of sustainable, highly reliable and corrosion resistant thermoplastic pumps and filters.

ARBO Pumps offer a remarkably longer life span and lower maintenance cost thanks to its ridged construction and solid material design.

With a team of experienced engineers, production- and sales staff, **ARBO** Pumps | Filters services a wide customer base and a wide range of duties through a worldwide distribution network of pump specialists.

We also deliver products corresponding to ATEX regulations.

PG 3.5 IMMERSIBLE CENTRIFUGAL PUMPS

SEALLESS



**COMPACT CONSTRUCTION
UP TO 300 M3/H**

In this series the pump is directly mounted onto the motor flange by means of a plastic bracket.



**LONG COUPLED CONSTRUCTION
UP TO 40 M3/H**

A number of models are available with bearing housing between the pump and the electric motor. Thanks to this construction it is possible to work without a foot bearing and makes it possible to mount longer pump shafts. This results in a lower minimum starting level in the tank.



MODEL BB:

Every ARBO immersible pump can be supplied in an "Out of tank" construction. The main advantage is the dry erection of the pump in situations where there is insufficient mounting space in the tank.



**ARBO
POMPEN EN FILTERS B.V.**

Leemdijk 2
9422 CL SMILDE
THE NETHERLANDS

T : +31 (0) 592 430 310

E : info@arbo-pumps.com
I : www.arbo-pumps.com

DISTRIBUTED BY: