

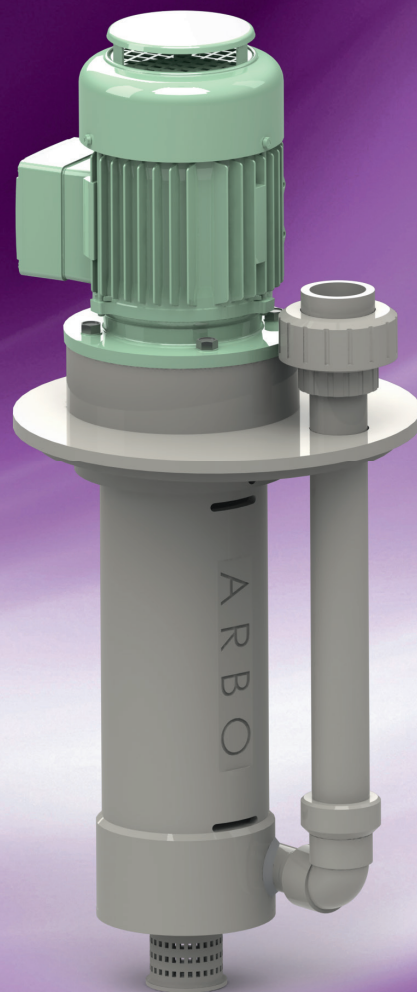

ARBO
THERMOPLASTIC
PUMPS
FILTERS



MODEL SUMPRO | SEAL-LESS IMMERSIBLE

PG 3.1 CENTRIFUGAL PUMPS

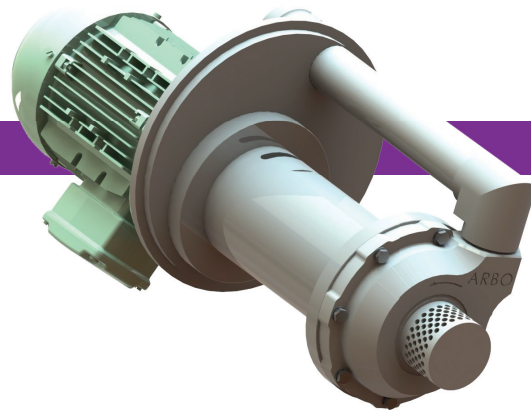

APPLICATIONS

For all transport or circulation duties of corrosive liquids, that may contain even high amount of particles or sludge with medium viscosity.

This series of pumps is equipped with a state of the art semi-open impeller that is fixed onto the shaft independent from the direction of rotation.

MATERIALS

Standard is the material PPH that covers a very wide range of duties.

For highly abrasive liquids (high percentage of solids), at special order, impellers or housing parts of High Modulus Polyethylene are available.

For highly corrosive mixtures of acids at higher temperatures even a pump housing entirely made of virgin PVDF is available.

For our smaller series, we can make PTFE pump housings to deal with strong alkaline at higher temperatures.

TECHNICAL DETAILS PUMPS

Design pressure	PN6
Design standard (BG1/2C)	DIN - EN 12157
Max. system pressure	not applicable; "open system"
Min. flow	BG1-3: 0,5 m ³ /h; BG4: 1 m ³ /h; BG5: 3 m ³ /h
Max. flow	45 m ³ /h
Max. head	56 m (60 Hz)
Max. viscosity	250 mPa·s
Max. solid size	3 mm

TECHNICAL DETAILS MOTORS

Standard	Three-phase, multivoltage, TEFC
High efficiency	IE2 efficiency level acc. IEC60034-30
Duty	Continuous duty: S1
Multi Voltage	220-240/380-415V 50 Hz // 440-460 V 60 Hz
Protection class	IP55 (IEC 34-5/ NEN-EN 60034-5)
Insulation Class	"F" (ΔT=80 C);
Max. ambient temperature	Ambient temperature: -30 to 40°C, at 1000 m.a.s.l.
Max. relative humidity	< 95%

OPTIONAL AVAILABLE

Other voltages	f.i. 480 V / 3 Ph / 60 Hz
Other insulation	f.i. Tropicalized
PTC Thermistors	on windings
Thermal or dust protection:	IP56, IP65, IP66, IPW56, IPW65 or IPW66

MATERIALS OF CONSTRUCTION	ABBREVIATION	T MIN. °C	T MAX. °C
Polypropylene	PP	0	80
High Modulus Polyethylene	HMPE	-50	80
Polyvinylidenfluoride	PVDF	-30	120
Polytetrafluorethylene*	PTFE	-40	140
Conductive plastics for ATEX-zones	PP/PVDF/PE-EL		

* BG1/2C with SS-316 shaft only

ORDERING CODE (P.I.C.)

Model	PUMP		MATERIALS				CONNECTION		MOTOR				
	Discharge size (D)	Housing size	Wetted parts	Impeller if different	Gas seal	Gaskets	Discharge (D)	Pole	Power kW	Voltage	Phase	Frequency	Atex
DO	15	55	PP	PVDF		E	R	2	0,12, 0,25	2	1	5	EX
	20	80	PVDF	HMPE	GD	V	RU	4	0,37, 0,55	3	3	6	
	25	95				T	CP		0,75, 1,1	4			
	32	125					BB		1,5, 2,2	6			
	40	160							3,0, 4,0				
	50								5,5				

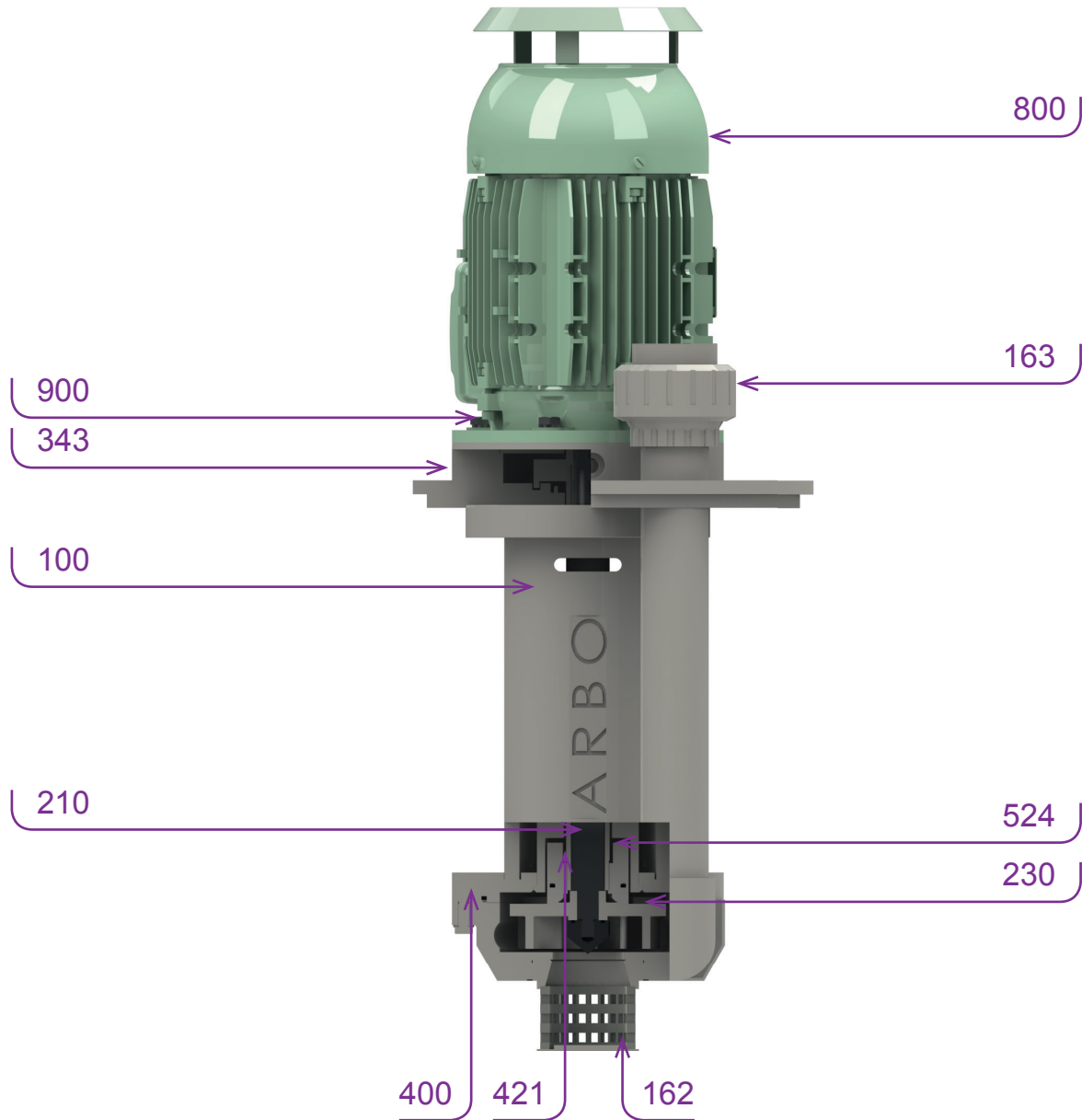

POS.	DESCRIPTION	STANDARD	ALTERNATIVES	
100	Housing parts	PPH	PVDF	PTFE
162	Suction adaptor	PPH	Extended suction pipe w. or w/o strainer	
163	Discharge adapter	R (+GF+ union bush)	RU (+GF+ 3D union)	CP- connection
210	Pump shaft	SS		
230	Impeller	PPH	HMPE	PVDF
	Impeller type	Semi-open	TW (turbine impeller)*	
343	Pump bracket	PPH		
400	Gaskets	EPDM	VITON	PTFE encapsulated
421	Mechanical seal	NONE; liquid seal	Gas seal	
524	Shaft protecting sleeve	PPH	HMPE	PVDF
800	Motor	2 or 4 pole		
900	Fasteners	SS-316	PEEK	Hasteloy C

* standard for BG5

FEATURES

Any kind of adapter can be ordered:

- R (+GF+ union bush)
- RU (+G.F.+ 3D-union)
- U (FIP union bush)
- H (Hose adapter)
- F (DIN or ANSI flanges)
- Model BB for out of tank

Labyrinth prevents fumes from the pump to exit into the atmosphere when the pump is operating:

- less motor corrosion
- better atmosphere around the pump

Optional:
unique gas seal available for extremely corrosive or dangerous liquids

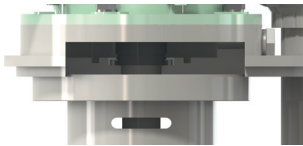

Motor optimized to run under tough conditions.

To ensure 100% sealing between pump and motor, even when the pump is not operating, a hose adapter 1/2" may be connected to a fresh air source.

Fume barrier protects motor shield and bearings against corrosion.

Semi-open impeller type:

- direction independent fixation
- for transfer and circulation
- increased efficiency = less energy consumption
- Turbine type available for low flow – high head applications
- very smooth and quiet
- air free operation, even at very low liquid level
- anti foam
- anti-clogging

Extra heavy duty lock nut for secure impeller fixation and shaft sealing.

Suction pipe with BSP thread so any kind of adapter can be used. Standard with large surface suction strainer.

Suction pipe extensions available.

SELECTION TABLE

PRODUCT GROUP 3.1 CONSTRUCTION SIZE (BG)	MODEL DO TYPE	IMPELLER SIZE Ø MM		PUMP PERFORMANCE		SG. MAX	MOTOR POWER KW	I NOM.
				Q. MAX	H. MAX	END-OF- CURVE	2850 MIN-1	400V/3PH/ 50HZ
		50 HZ	60 HZ	M3/H	M	(P) KG/M3	50 HZ	A
1C	15-55	55	50	3,8	3,0	1500	0,12	0,45
	15-80	80	65	5,5	7,0	1500	0,25	0,65
2C	25-80	80	65	7,0	7,0	1200	0,25	0,65
2	20-80	80	65	4,5	7,0	1200	0,25	0,65
3	25-85	85	70	9,1	9,0	1200	0,37	0,96
	32-95	95	80	13,0	12,0	1150	0,55	1,4
4	40-125	85	70	18,2	8,5	1150	0,75	1,7
	40-125	95	80	21,5	12,0	1200	1,1	2,4
	40-125	105	90	25,0	15,0	1150	1,5	3,2
	40-125	115	95	30,0	18,0	1150	2,2	4,5
	40-125	125TW	105TW	20,0	25,0	1100	2,2	4,5
	40-125	125TW	105TW	25,0	25,0	1250	3,0	5,9
5	40-160	145	120	35,0	32,0	1200	5,5	10,5
	40-160	160	135	30,0	39,0	1200	5,5	10,5
	50-160	130	110	42,0	29,0	1200	5,5	10,5
	50-160	140	115	45,0	24,0	1200	5,5	10,5

Immersible pumps on scrubbers





SUCTION PIPE

In order to empty deep sumps ARBO offers suction pipe extension up to a total immersible length of 3 mtr.!

Extended suction pipes are split into sections of 1.2 mtr. maximum for easy transport.

It is recommended to support long suction pipes to the sump wall, however these supports need some flexibility and should not cause vibration.

FOOTVALVE (FOR CLEAN SOLUTIONS ONLY)

If starting at any level is requested, ARBO offers a very reliable corrosion resistant foot valve to maintain the liquid level inside the pump housing.

Filled once, the pump is able to start again even though the liquid level in the sump is below the impeller housing.

THIS CONSTRUCTION FEATURES:

- Maintenance free operation over long working life
- Service friendliness
- Radial installation/removal
- Quick and precise opening and closing
- Low opening pressure of 0.025 Bar

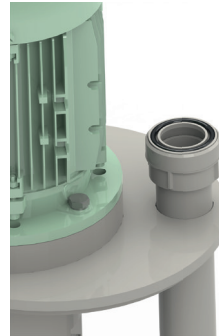

DISCHARGE CONNECTIONS

For easy installation of the pump into your piping system, ARBO offers several connections and adaptors. For maximum flexibility the threaded R connection is standard. This is a +GF+ union bush that will adapt any kind of mail straight pipe thread fitting and is supplied complete with O-ring.

OPTIONAL

You may wish to order different counter parts in f.i. PVC or PE to match your piping.



Union nut



Union end

Should you request a complete 3D +G.F.+ union, please order "RU".

U-EXECUTION

Should you like to have a replacement pump for your existing process that is equipped with FIP fittings, please order U execution. It will come complete with O-ring.



CP-EXECUTION

Offers some cost reduction and more flexibility to machine makers who want to use own build-in discharge piping. There is a threaded connection directly to the impeller housing.

PERFORMANCE CURVES DO-BG1-2C

PERFORMANCE CURVES **2-pole motors 50 - 60 Hz**

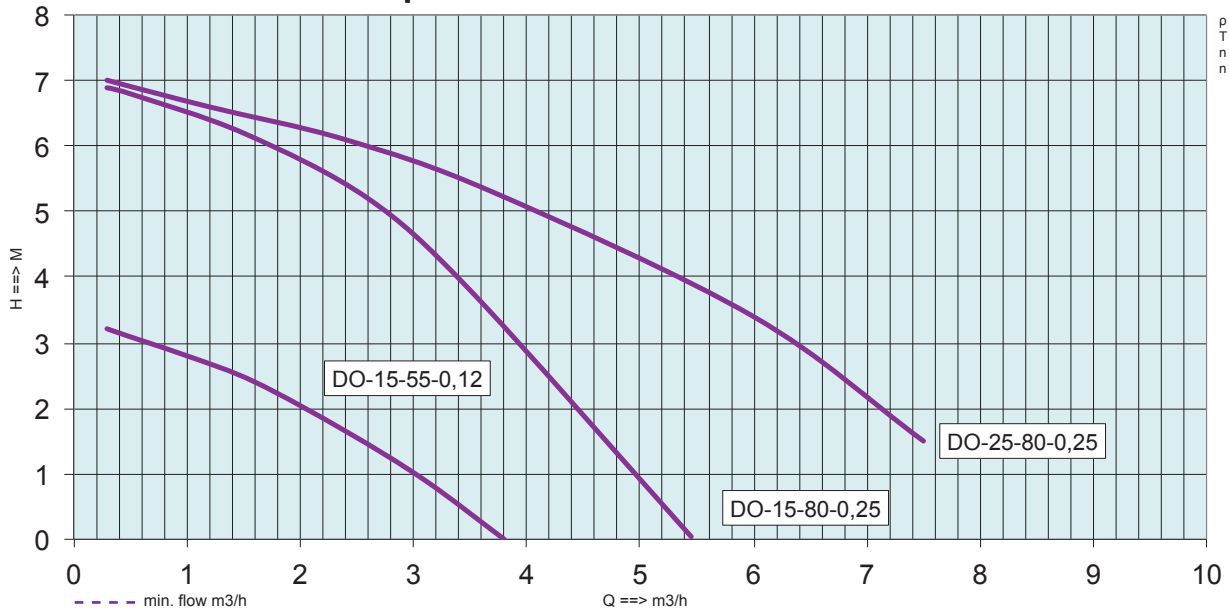

POWER CURVES **2-pole motors 50 - 60 Hz**

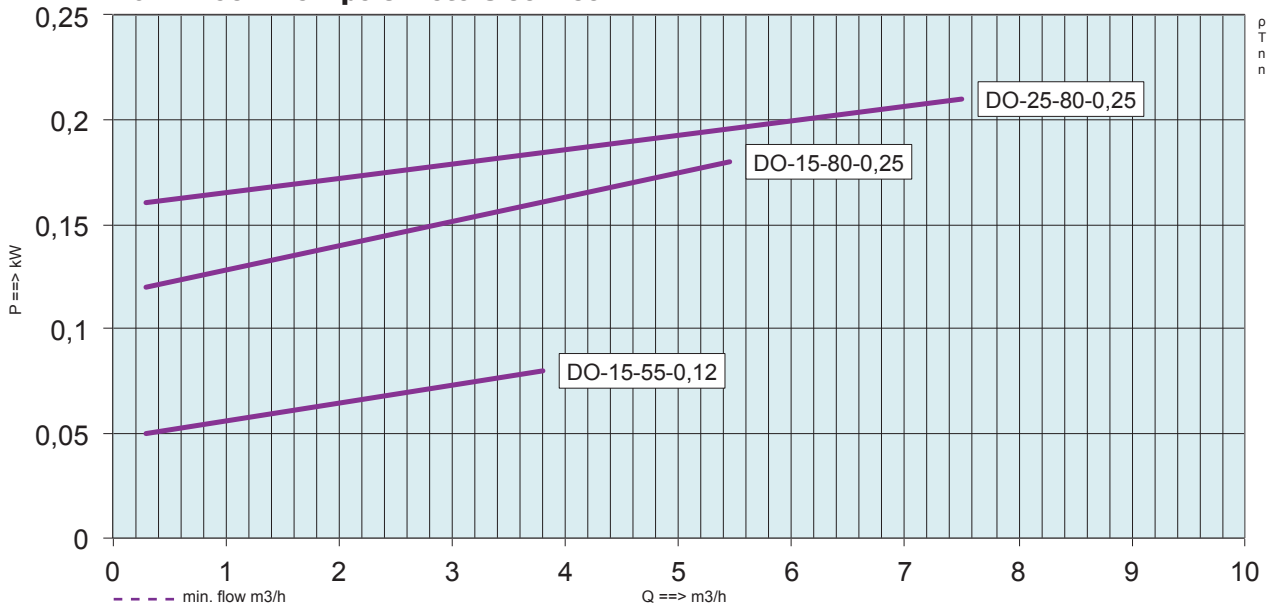

DIMENSIONS / WEIGHTS DO-BG1-2C

DO	MOTOR	IMPELLER Ø MM		WEIGHT KG		BOX SIZE	PACKAGING
		MIN.	MAX.	PP	PVDF		
15-55	63M	55	55	6	8	81x42x42	6
15-80	63M	55	80	6	8	81x42x42	6
25-80	63M	55	80	6	8	81x42x42	6

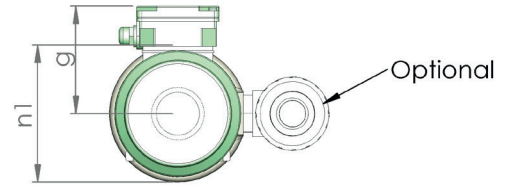

SPECIAL

Customized mounting plate

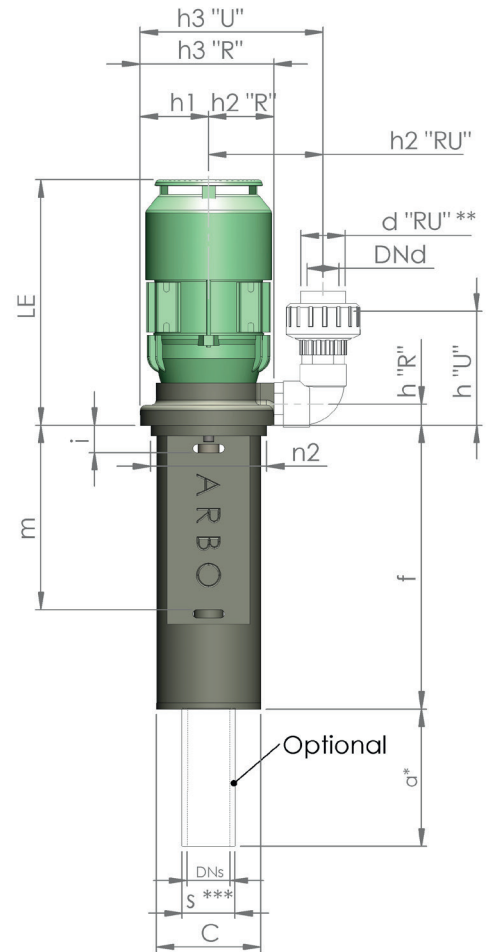
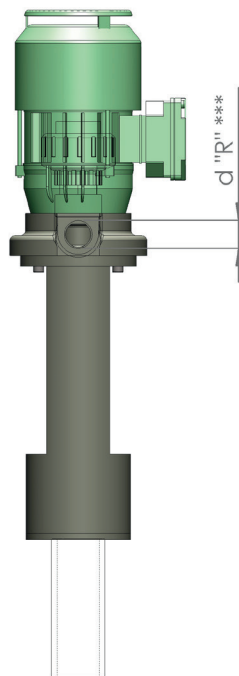
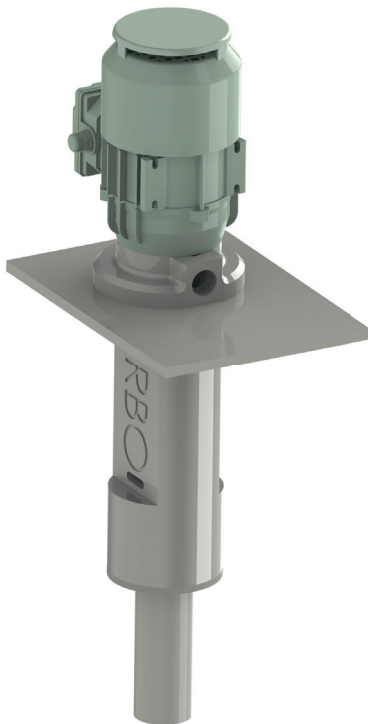

DO	MOTOR	DIMENSIONS (MM)																			MAX.	
TYPE	IEC	a*	C	g	h1	h2 "R"	h2 "RU"	h3 R	h3 "RU"	h "R"	h "RU"	i	m	n1	n2	DNd	d "R"	d "RU"	DNs	s	f	LE
15-55	63M	*	99	105	65	62,5	110	127,5	175	20	95	50	173	130	110	20	3/4"	1 1/4"	32	2"	270	195
15-80	63M	*	99	105	65	62,5	110	127,5	175	20	95	50	173	130	110	20	3/4"	1 1/4"	32	2"	270	195
25-80	63M	*	99	105	65	62,5	110	127,5	175	20	95	50	173	130	110	25	1"	1 1/2"	32	2"	270	195

* extension to max. 1000 mm total immersible length
 ** male straight pipe thread
 *** female straight pipe thread

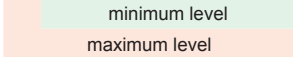

PERFORMANCE CURVES DO BG 2-3

PERFORMANCE CURVES **2-pole motors 50 - 60 Hz**

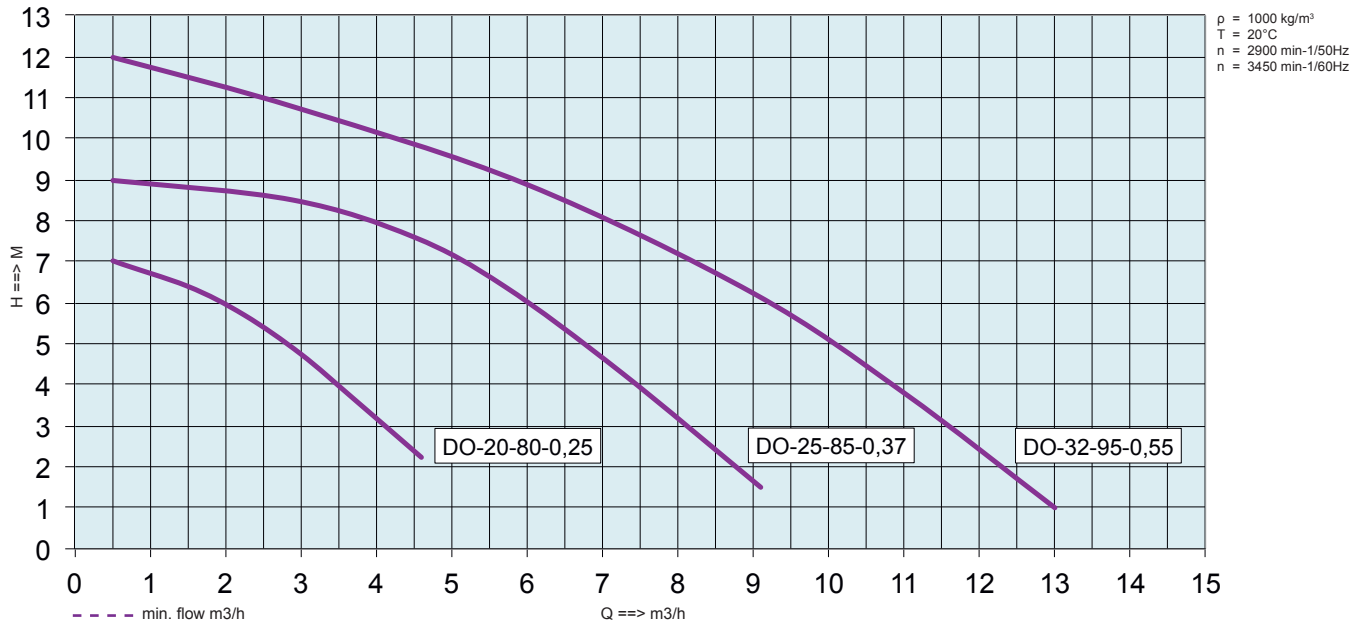

POWER CURVES **2-pole motors 50 - 60 Hz**

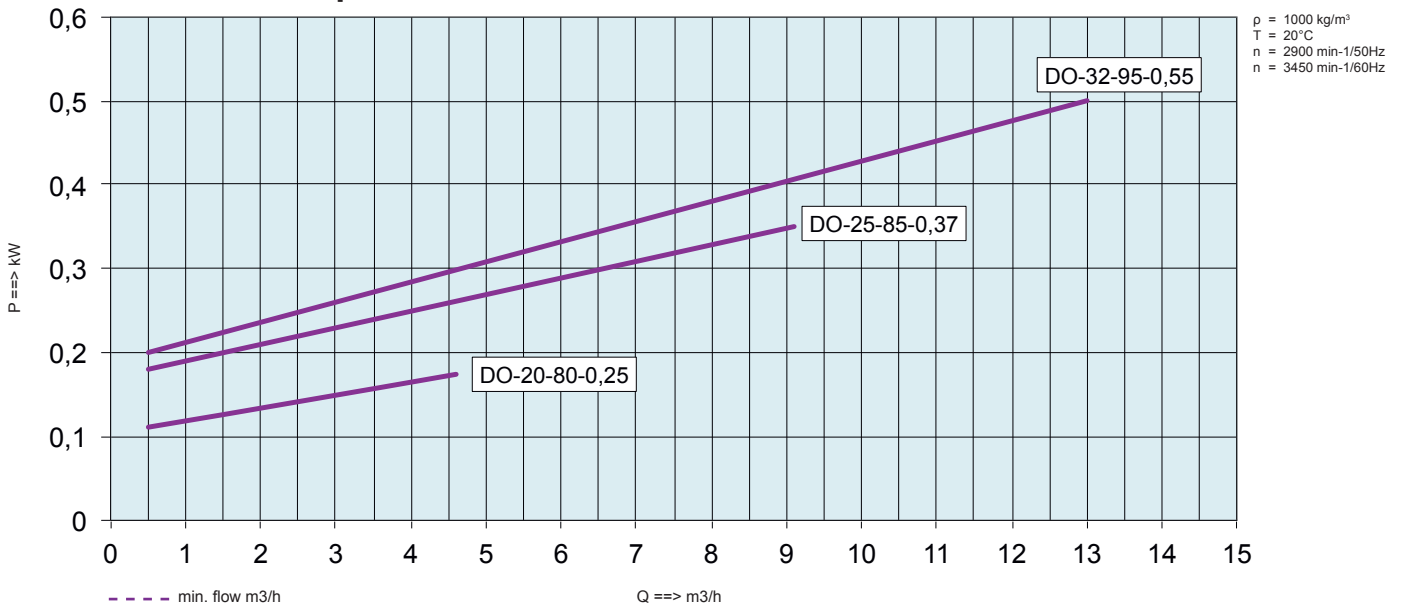

PERFORMANCE CURVES DO BG 4

PERFORMANCE CURVES **2-pole motors 50 - 60 Hz**

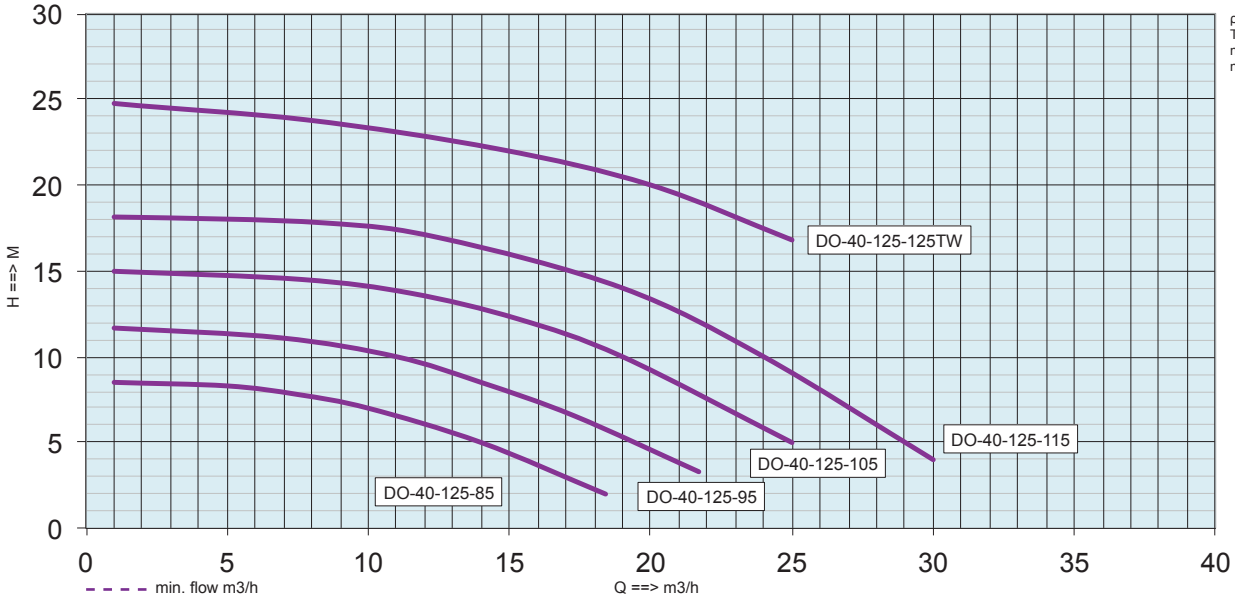

$\rho = 1000 \text{ kg/m}^3$
 $T = 20^\circ\text{C}$
 $n = 2900 \text{ min-1/50Hz}$
 $n = 3450 \text{ min-1/60Hz}$

POWER CURVES **2-pole motors 50 - 60 Hz**

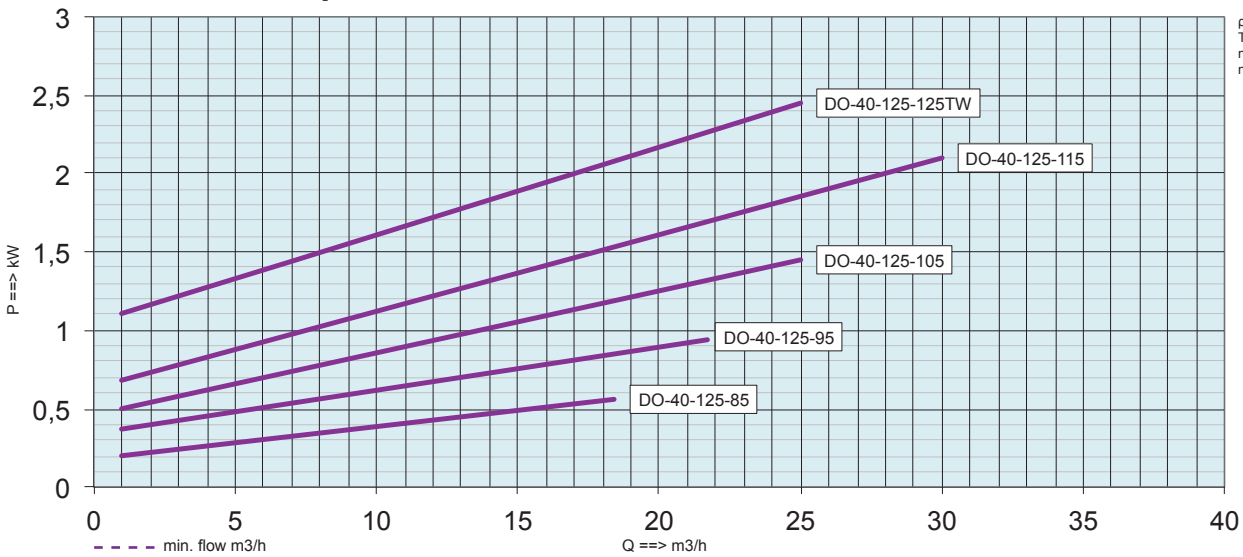

$\rho = 1000 \text{ kg/m}^3$
 $T = 20^\circ\text{C}$
 $n = 2900 \text{ min-1/50Hz}$
 $n = 3450 \text{ min-1/60Hz}$

PERFORMANCE CURVES **2-pole motors 50 - 60 Hz**

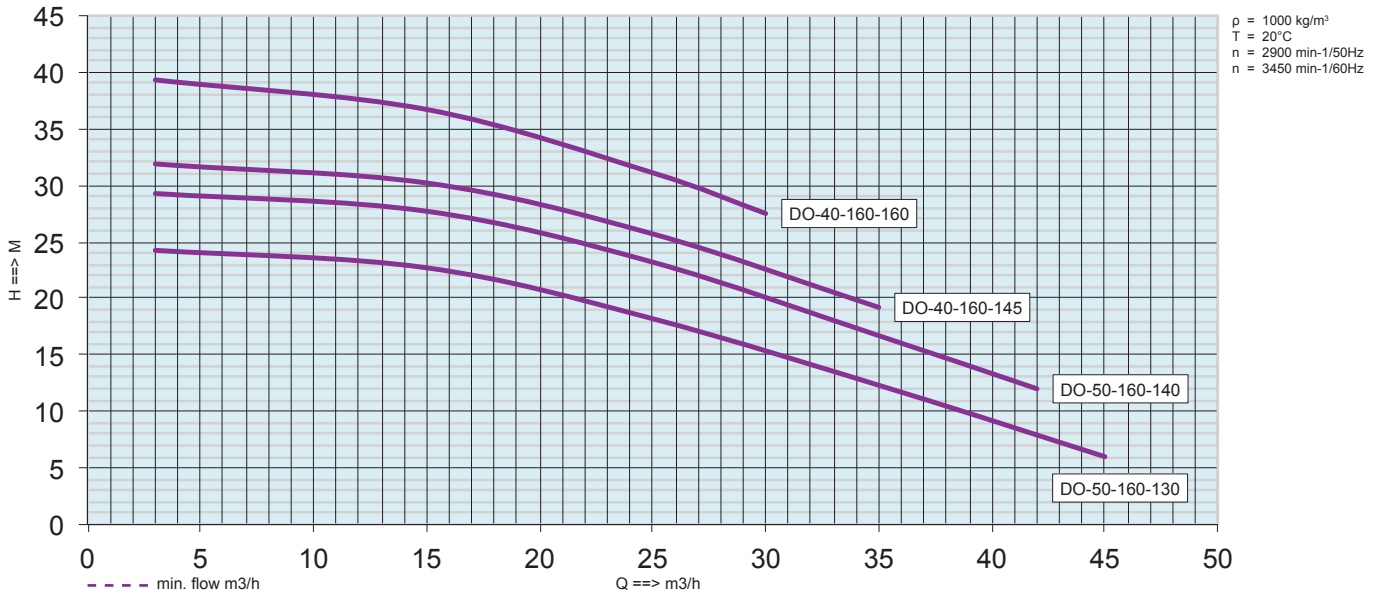

POWER CURVES **2-pole motors 50 - 60 Hz**

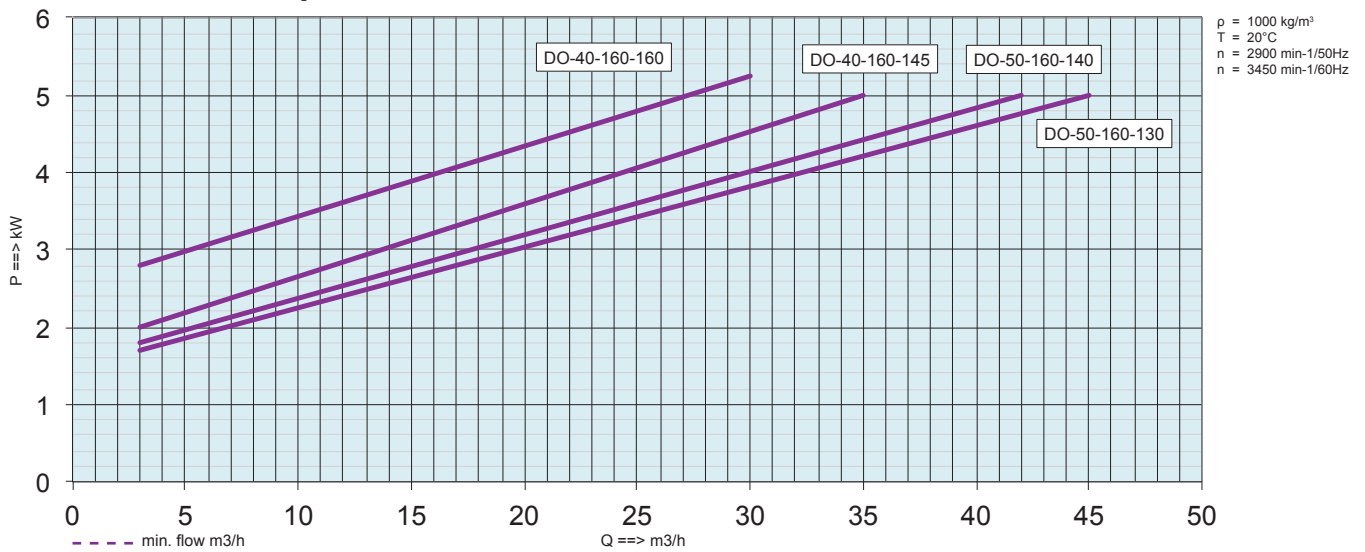

DIMENSIONS / WEIGHTS DO-BG 2-5

DO	MOTOR	IMPELLER Ø MM		WEIGHT KG		BOX SIZE	PACKAGING
		MIN.	MAX.	PP	PVDF		
20-80	63M	70	85	12	14	81x42x42	6
25-85	71M	70	85	12	14	81x42x42	6
32-95	71M	70	95	13,5	18,0	81x42x42	6
40-125	80M	80	95	18,5	24,5	91x44x43	8
40-125	90S	80	125	21	27,0	91x44x43	10
40-125	90L	80	125	23,5	27,0	91x44x43	10
50-125	100L	80	125	32	38,0	101x52x53	10
40-160	112M	125	160	52	59,0	101x52x53	10
50-160	112M	125	140	53	60,0	101x52x53	10
50-160	112M	125	140	53	60,0	101x52x53	10

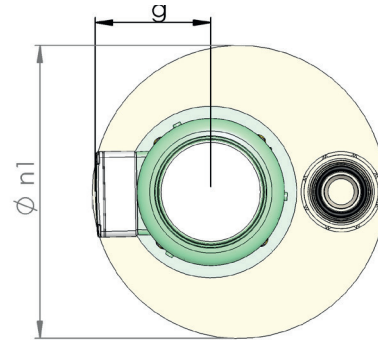

SPECIAL

Execution with customized U connection and Gas seal for etching applications

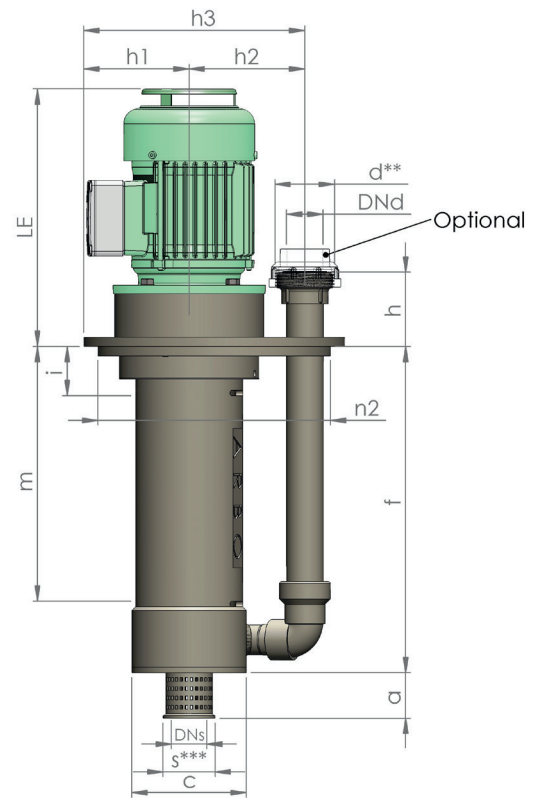
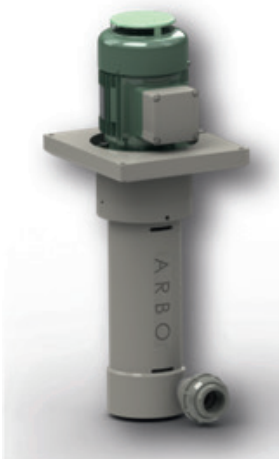

DO	MOTOR	DIMENSIONS (MM)														MAX.		
		a*	C	g	h1	h2	h3	h	i	m	n1	n2	DNd	d	DNs		s	f
20-80	63M	49	123	115	100	110	210	80	50	280	250	220	20	1 1/4"	32	2"	358	270
25-85	71M	49	123	110	113	127	240	80	50	280	250	220	25	1 1/2"	32	2"	358	270
32-95	71M	49	123	110	113	127	240	80	50	280	280	250	32	2"	32	2"	358	270
40-125	80M	53	200	140	110	153,5	263,5	80	55	265	300	280	40	2 1/4"	50	2 3/4"	359	310
40-125	90S	53	200	155	110	153,5	263,5	80	55	265	300	280	40	2 1/4"	50	2 3/4"	359	360
40-125	90L	53	200	155	110	153,5	263,5	80	55	265	300	280	40	2 1/4"	50	2 3/4"	359	360
50-125	100L	53	254	184	112	175,0	296	80	55	265	345	325	50	2 3/4"	50	2 3/4"	359	390
40-160	112M	53	254	184	136	190,0	326	80	55	265	375	355	40	2 1/4"	50	2 3/4"	359	430
50-160	112M	53	254	184	136	190	326	80	55	265	375	355	50	2 3/4"	50	2 3/4"	359	430
50-160	112M	53	254	184	136	190	326	80	55	265	375	355	50	2 3/4"	50	2 3/4"	359	430

* extension to max. 1000 mm total immersible length

** male straight pipe thread

*** female straight pipe thread

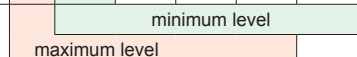

DIMENSIONS / WEIGHTS DO-BG 2-4 CP

DO	MOTOR	IMPELLER Ø MM		WEIGHT KG		BOX SIZE	PACKAGING
		MIN.	MAX.	PP	PVDF		
20-80	63M	70	85	12	14	81x42x42	6
25-85	71M	70	85	12	14	81x42x42	6
32-95	71M	70	95	13,5	15,5	81x42x42	6
32-125	80M	80	95	18,5	21,0	91x44x43	8
40-125	90S	80	125	21	24,0	91x44x43	10
40-125	90L	80	125	23,5	27,0	91x44x43	10
50-125	90L	80	125	23,5	27,0	101x52x53	10
50-125	90L	80	125	23,5	27,0	101x52x53	10

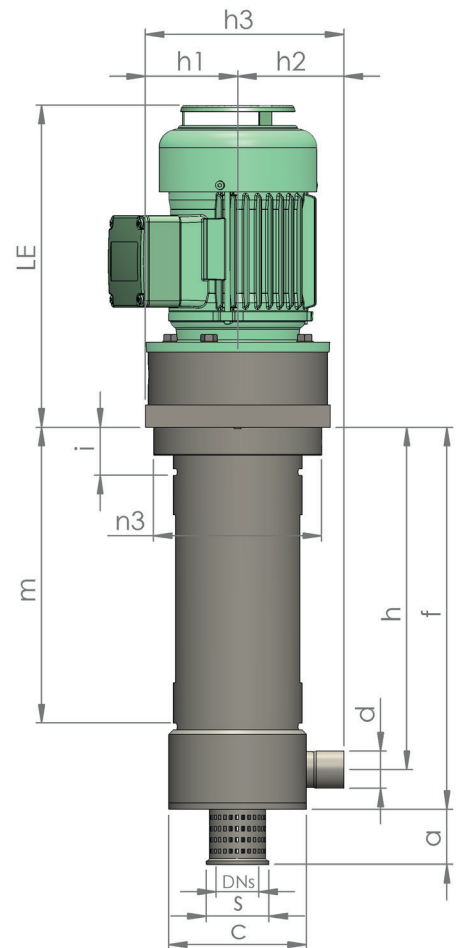
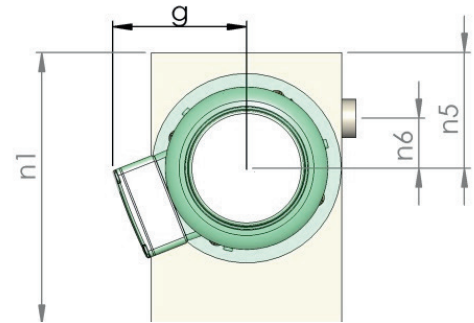
SPECIAL

CP execution with customized mounting plate

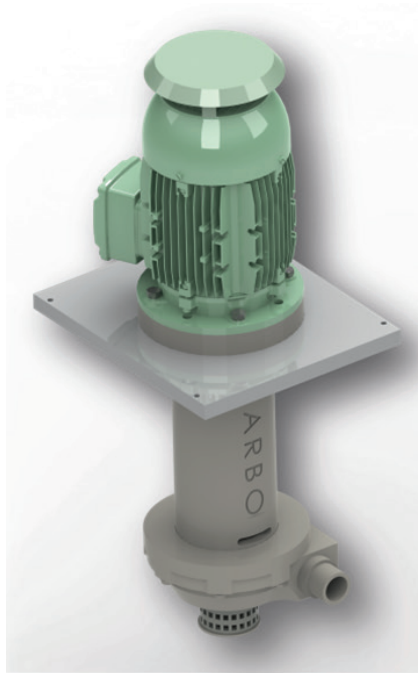

DO	MOTOR	DIMENSIONS (MM)																		MAX.
		a*	C	g	h1	h2	h3	H	i	m	n1	n3	n4	n5	n6	d**	DNs	s***	f	
20-80	63M	49	123	92	73	73	146	305	40	270	203	140	146	100	42,5	3/4"	32	2"	358	270
25-85	71M	49	123	122	82,5	95	177,5	305	40	270	235	150	165	100	42,5	1"	32	2"	358	270
32-95	71M	49	123	122	82,5	95	177,5	305	40	270	235	150	165	100	42,5	1"	32	2"	358	270
32-125	80M	53	200	149	102,5	114,5	217	319	45	255	300	180	205	125	62,5	1"	50	2 3/4"	359	320
40-125	90S	53	200	149	102,5	114,5	217	319	45	255	300	180	205	125	62,5	1 1/2"	50	2 3/4"	359	370
40-125	90L	53	200	149	102,5	114,5	217	319	45	255	300	180	205	125	62,5	1 1/2"	50	2 3/4"	359	370
50-125	90L	53	200	149	102,5	114,5	217	319	45	255	300	180	205	114	52,5	1 1/2"	50	2 3/4"	359	370
50-125	90L	53	200	149	102,5	114,5	217	319	45	255	300	180	205	114	52,5	1 1/2"	50	2 3/4"	359	370

* extension to max. 3000 mm total immersible length

** male straight pipe thread

*** female straight pipe thread

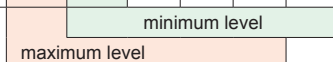

MODEL BB

This pump, for 'out of tank' use offers the same advantages as the standard Sumpro series.

DRY RUN RESISTANT

Although the pump is "dry-mounted" it can be run dry without damage as there is no seal and no bearing in the pump housing. An advantage when handling abrasive or crystallizing liquids.

SPACE EFFECTIVE

Additional advantages are that it can be used where there is insufficient space inside the tank, and that it can pump over a second circuit by tapping the suction pipe, for example, for pre-coating or flushing operations.

CORROSION RESISTANT

There is no metal to liquid contact; wetted parts of the pump can be PP or PVDF according to suitability for the intended use. Gaskets of EPDM are standard and optional are Viton or PTFE-encapsulated O-rings.

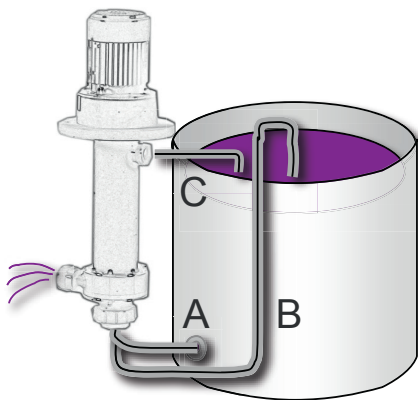
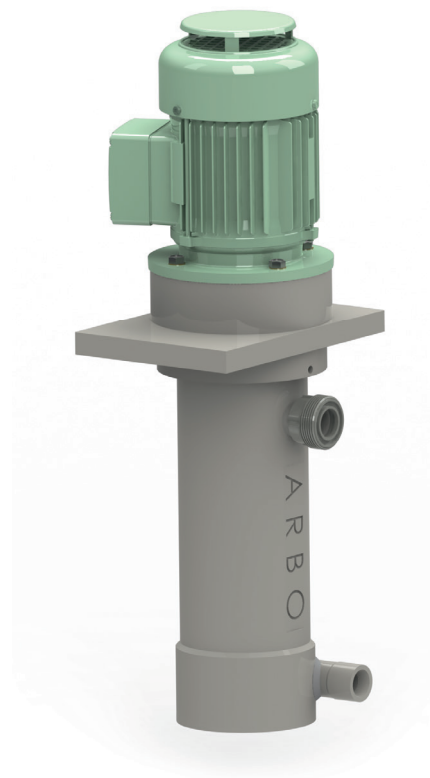

The suction pipe can be connected directly through the tank wall (A) or it can be in the form of a siphon pipe (B), as shown in the drawing.

In the event of a closed valve on the discharge pipe, the overflow pipe (C) relieves pressure by conducting the liquid back into the tank.

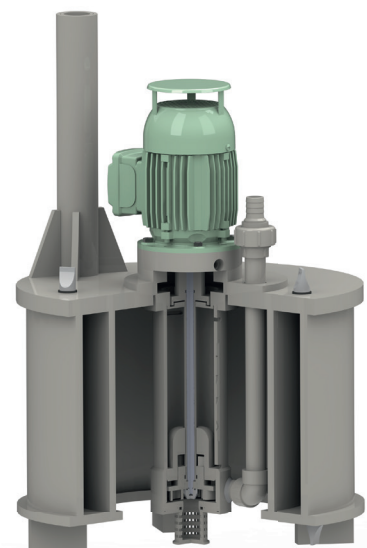

Model DO-D floating immersible pump

DIMENSIONS / WEIGHTS DO-BG3-4 BB

DO	MOTOR	IMPELLER Ø MM		WEIGHT KG		BOX SIZE	PACKAGING
		MIN.	MAX.	PP	PVDF	CM	
25-85	71M	70	85	12	14	81x42x42	6
32-95	71M	70	95	13,5	15,5	81x42x42	6
40-125	80M	80	95	18,5	21,0	91x44x43	8
40-125	90S	80	125	21	24,0	101x52x53	10
40-125	90L	80	125	23,5	27,0	101x52x53	10
40-125	90L	80	125	23,5	27,0	101x52x53	10

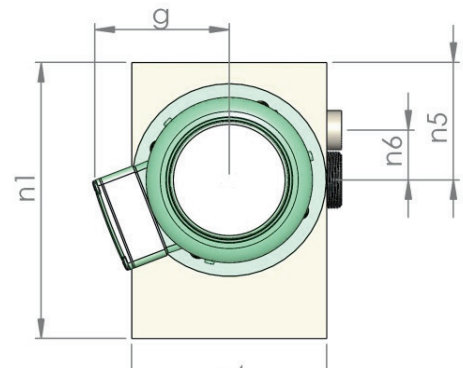
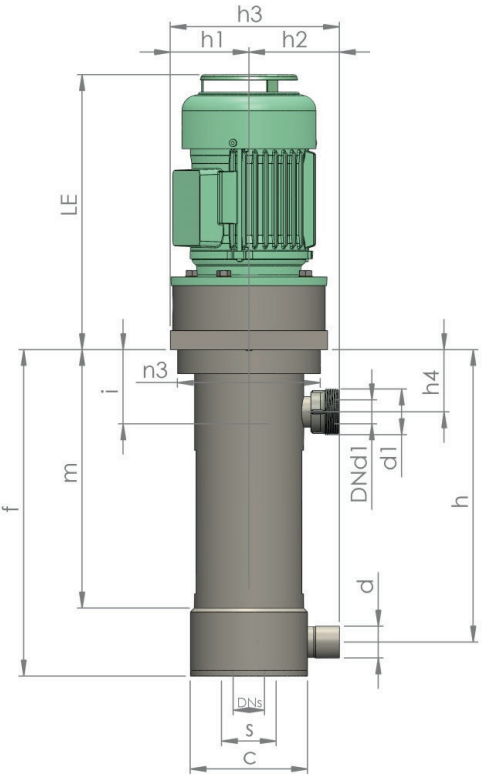

DO	MOTOR	DIMENSIONS (MM)																		MAX.		
		C	g	h1	h2	h3	h4	h	i	m	n1	n3	n4	n5	n6	d**	DNd1	d1**	DNs		s***	f
25-85	71M	123	122	82,5	95	177,5	65	305	100	270	235	150	165	100	42,5	1"	25	1"	32	2"	358	270
32-95	71M	123	122	82,5	95	177,5	65	305	100	270	235	150	165	100	42,5	1"	25	1"	32	2"	358	270
40-125	80M	200	149	102,5	114	216,5	65	319	100	270	300	180	205	124,5	62,5	1 1/2"	50	2 3/4"	50	2 3/4"	359	310
40-125	90S	200	149	102,5	114	216,5	65	319	100	270	300	180	205	124,5	62,5	1 1/2"	50	2 3/4"	50	2 3/4"	359	360
40-125	90L	200	149	102,5	114	216,5	65	319	100	270	300	180	205	124,5	62,5	1 1/2"	50	2 3/4"	50	2 3/4"	359	360
40-125	90L	200	149	102,5	114	216,5	65	319	100	270	300	180	205	124,5	62,5	1 1/2"	32	2"	50	2 3/4"	359	360

** male straight pipe thread

*** female straight pipe thread

 minimum level
 maximum level

PG 3.1 IMMERSIBLE CENTRIFUGAL PUMPS

SEALLESS



**COMPACT CONSTRUCTION
UP TO 300 M3/H**

In this series the pump is directly mounted onto the motor flange by means of a plastic bracket.



**LONG COUPLED CONSTRUCTION
UP TO 40 M3/H**

A number of models are available with bearing housing between the pump and the electric motor. Thanks to this construction it is possible to work without a foot bearing and makes it possible to mount longer pump shafts. This results in a lower minimum starting level in the tank.



MODEL BB:

Every ARBO immersible pump can be supplied in an "Out of tank" construction. The main advantage is the dry erection of the pump in situations where there is insufficient mounting space in the tank.



**ARBO
POMPEN EN FILTERS B.V.**

Leemdijk 2
9422 CL SMILDE
THE NETHERLANDS

T : +31 (0) 592 430 310

E : info@arbo-pumps.com
I : www.arbo-pumps.com

DISTRIBUTED BY: