

### Pump construction

Motor Mounting IEC-V1 standard.

Universal Flanges Connections that meet DIN PN16 and ANSI 150#.

### Performance curves

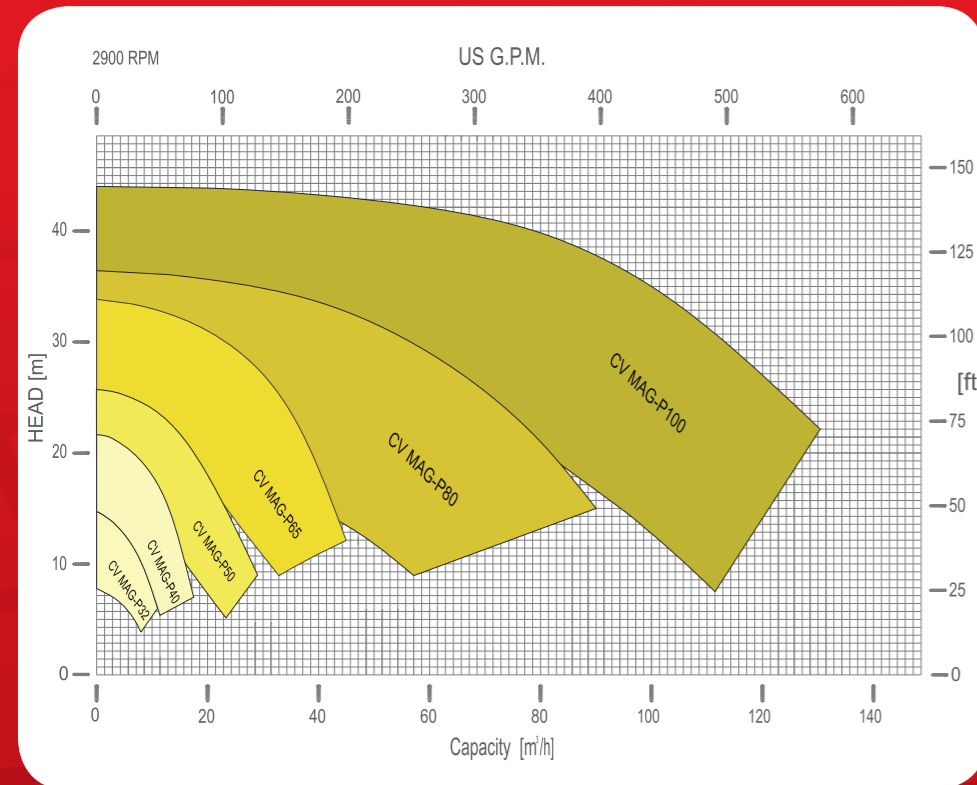

### Operating Limits

- Max viscosity: 200 cSt
- Flow up: to 140 mc/h
- Head up: to 44 m
- Temperature range: from -22 °F (-30 °C) to +194 °F (+90 °C)
- Electric motors: from 1,5 up to 18,5kW
- Length up: to 7 m

## VERTICAL, SEALLESS PP AND PVDF ARMORED CENTRIFUGAL PUMP WITH PERMANENT MAGNET DRIVE SYSTEM, NO MECHANICAL SEAL

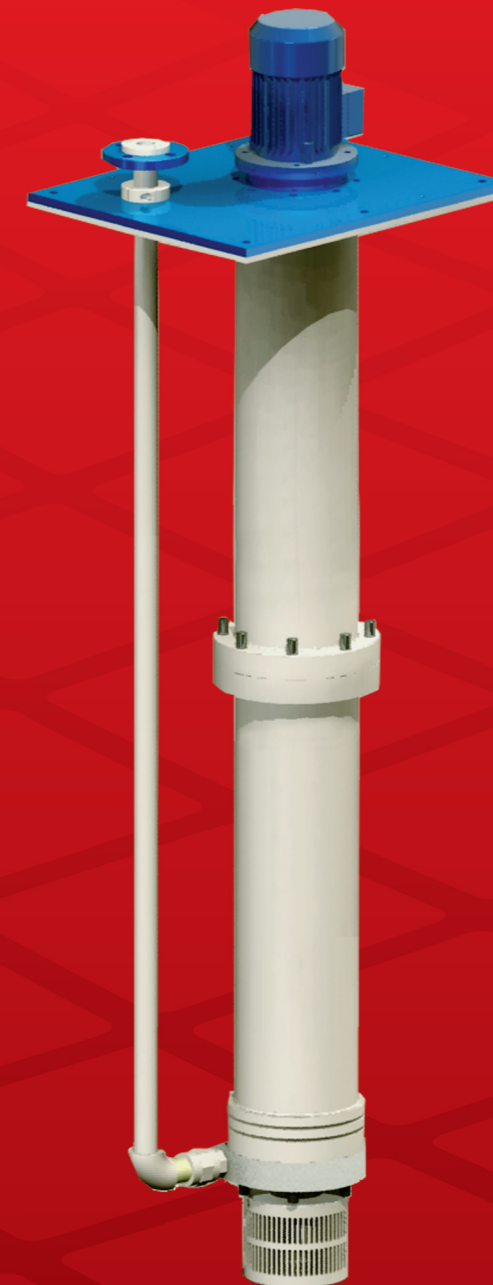

# CV MAG-P

Manufactured by:



A unit of  
**Mischiatti**  
GROUP

**M PUMPS s.r.l.** - Via dell'Artigianato, 120  
45015 Corbola (Ro) - Italy - [www.mpumps.it](http://www.mpumps.it)  
Tel. +39 0426 346304 - Fax +39 0426 349126

For more information please contact:



### CV MAG-P Series

The separation of liquid chamber/atmosphere by means of an isolation shell is the best solution to pump aggressive chemical, high purity liquids and liquids difficult to seal. The hermetic sealless is the best solution for the chemical and pharmaceutical industry. A wide range of pumps covers the different performances. Robust construction combined with high wall thickness guarantees a long life against the corrosion.

# PUMP DETAILS

The sealing system with O-Rings prevents from leaking in the atmosphere – different materials are available:

- EPDM
- VITON®

Epoxy primer and polyacrylic enamel water-based painting for the best quality resistance linked to the environmental respect.

Strong carbon steel CNC machined construction, protected by an high thickness thermoplastic shell, to reach the best compromise between mechanical and corrosion resistance.

High thickness thermoplastic barrier to avoid any possibility of corrosion.

Special PVDF FCR screws for external parts in contact with the liquid.

**RWP QUICK CHANGE CARTRIDGE KIT** to guarantee an easy and fast maintenance, PP and PVDF materials.

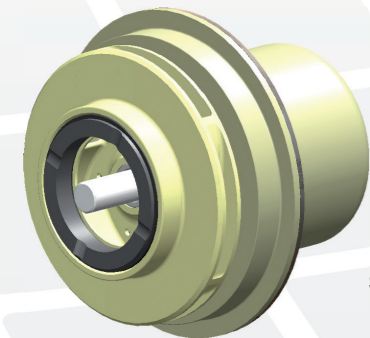

Standard version

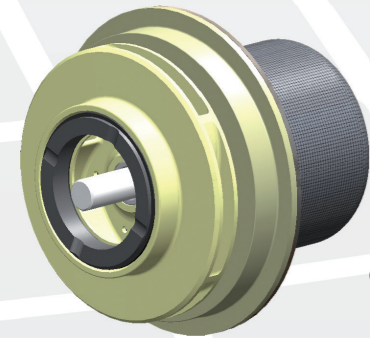

CFR version

Pump casing shall be one single piece, achieved from solid bar, made of very high thickness PP and PVDF to have a good mechanical resistance and a guaranteed long life against the corrosion.

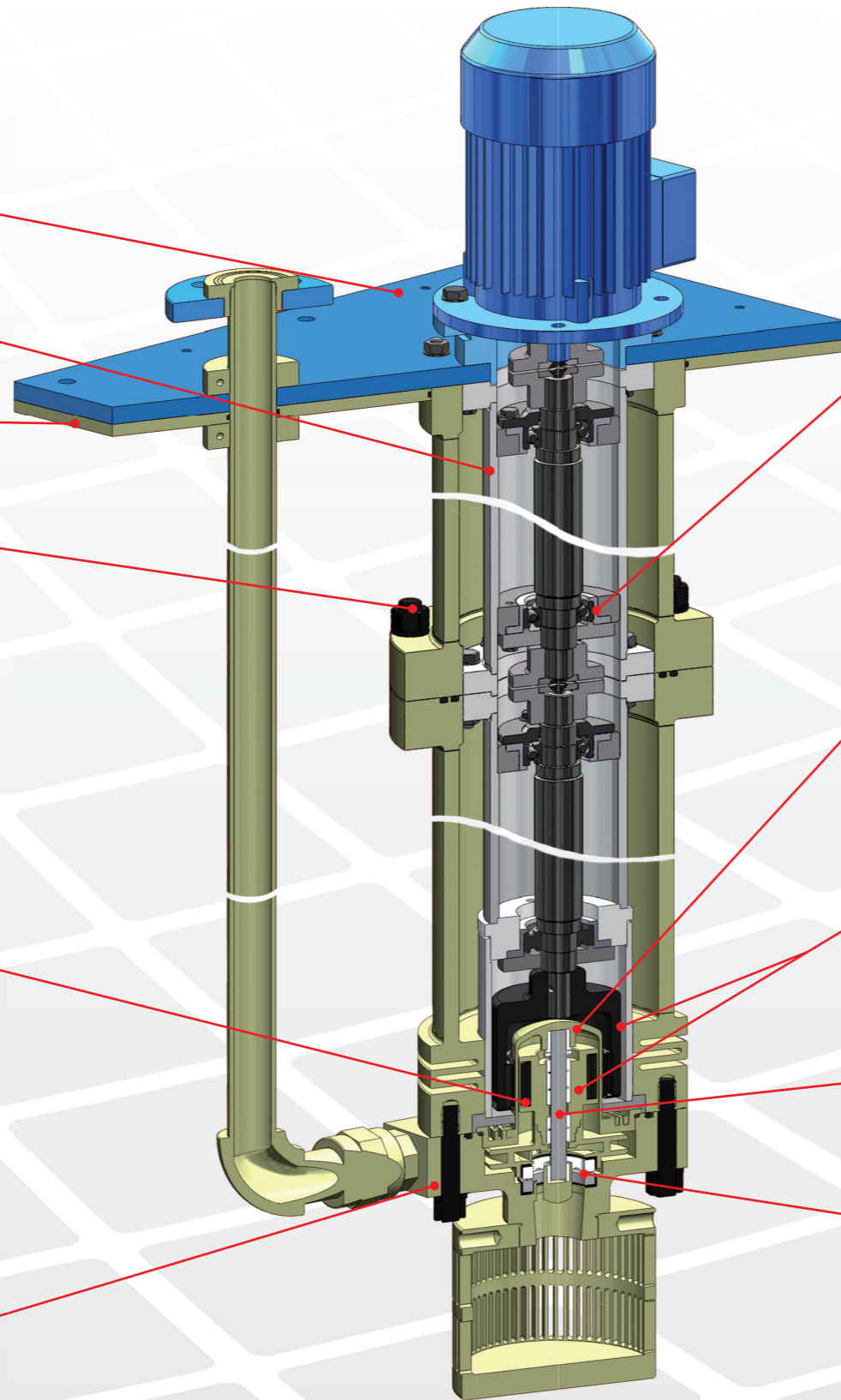

Ball bearings sealed for life (Lh=30000 hours) to support the shaft line, smart additional modules that allows arrive up to 7 m depth.

The rear shell is made of thermoplastic materials, as PP GFR or PVDF CFR with zero magnetic losses. Outside rear shell cover ellipsoidal profile made of fiber reinforced composite material.

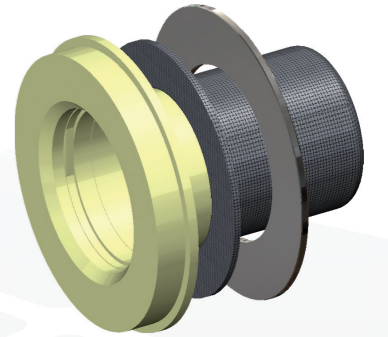

High power synchronous magnetic coupling designed by our Technical Office and with magnetic elements mechanically locked.

**Rare earth guarantees the magnetic-balancing to avoid the thrust bearing wear and the heat generation.**

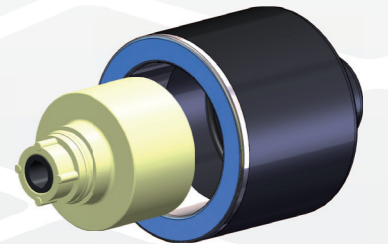

Field assembling of the product lubricated bearing arrangement does not require special tools.

The Shaft / Bearing materials are available in three different configurations to provide the best solution for each application:

- PTFEC – ALLUMINA 99,7% (standard)
- CARBON – ALLUMINA 99,7%
- Silicon Carbide (SSIC) – Silicon Carbide (SSIC)

