

Typical Applications:



Freeze Drying Units

Thermoregulation Units for injection moulds

Cooling of Radar Devices

Cooling of Eolic generators

Pump construction

Close-coupled drivers are conventional drivers mounted directly to pumps frame. No base, coupling or guards are required for this mounting style.

Connections:

Threaded 1/2" BSP (GAS) & NPT.

Operating Limits

- Max viscosity: 200 cSt
- Max system pressure: 16 bar (standard)
Higher pressure version available on request.
- Flow up: to 1.5 mc/h
- Head up: to 85 m
- Temperature range: from -185 °F (-120 °C) to +662 °F (+350 °C)
- Electric motors: from 0,37kW up to 2,2 kW
- Available ATEX II - / 2G cbk II C T2 - T5

Performance curves

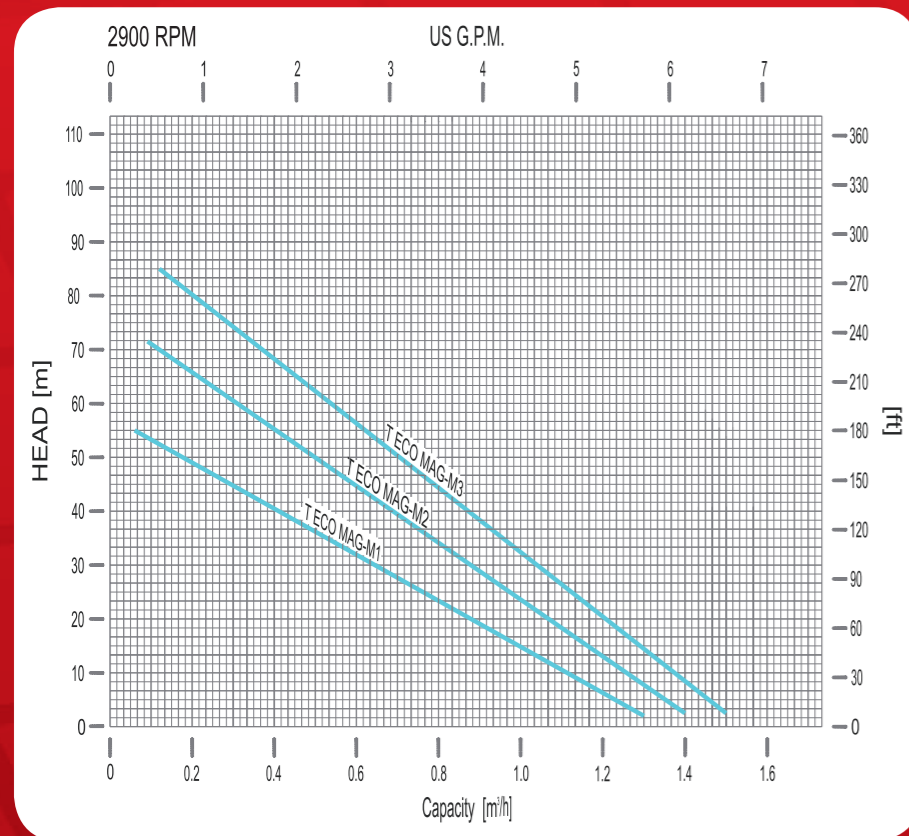

HORIZONTAL, SEALLESS PERIPHERAL PUMP WITH PERMANENT MAGNET DRIVE SYSTEM NO MECHANICAL SEAL

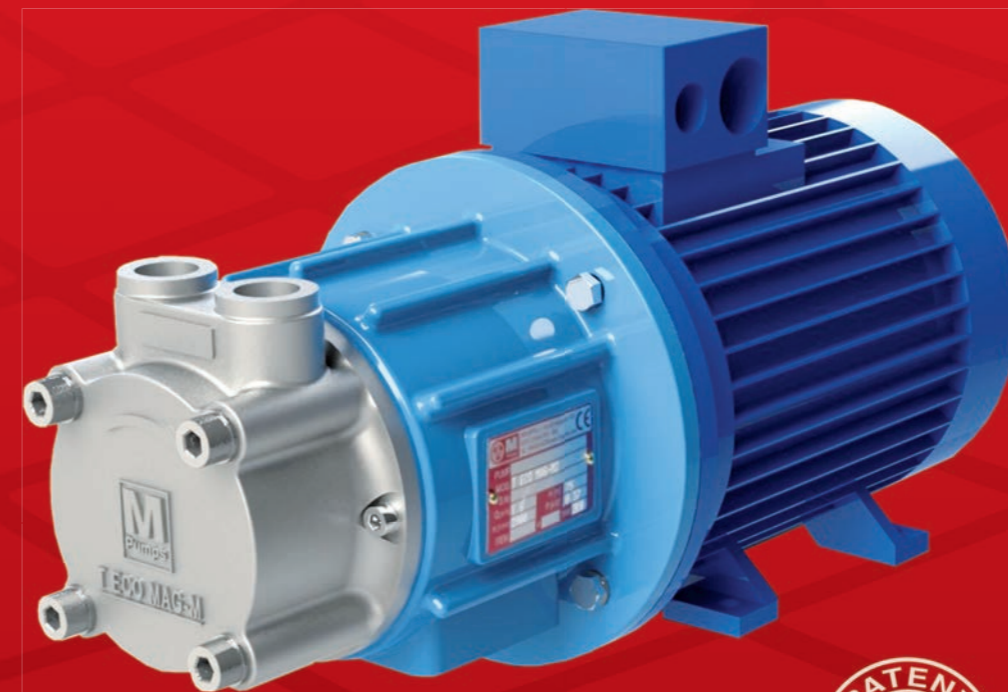

FILE NUMBER: PD2010A000179

T ECO MAG-M

Manufactured by:



A unit of
Mischiatti
GROUP

M PUMPS s.r.l. - Via dell'Artigianato, 120
45015 Corbola (Ro) - Italy - www.mpumps.it
Tel. +39 0426 346304 - Fax +39 0426 349126

For more information please contact:



ISO 14001:2004

273

T ECO MAG-M Series

The separation of liquid chamber/atmosphere by means of an isolation shell is the best solution to pump aggressive, explosive and toxic liquids, hydrocarbons, heat transfer liquids and liquids difficult to seal. The hermetic sealless is the best solution for the chemical, pharmaceutical and petrochemical industry. Low flow and high heads are the main characteristics of this pump design.



PUMP DETAILS

The rear shell is made of one single piece, no welding, special profile that has been studied to withstand higher pressures than the traditional one. The material is AISI 316; system pressure max 16 bar.



Particular design of the hydraulic, with self balancing impeller to improve the wear ring life. Field assembling of the product lubricated bearing arrangement does not require special tools. The Volute/Bearing materials are available in two different types to provide the best solution for each application: Carbon graphite volutes with stainless steel shaft and Antimony carbon volutes with Silicon Carbide shaft.



CF8M Pump Casing & Impeller High quality casting components, CNC machined with high accuracy, for the best performance.

RWP QUICK CHANGE CARTRIDGE KIT to guarantee an easy and fast maintenance.



The sealing system with O-ring gaskets prevents product from leaking in the atmosphere – different materials available:

- VITON® (standard)
- GRAPHOIL
- ARAMIDIC
- FEP

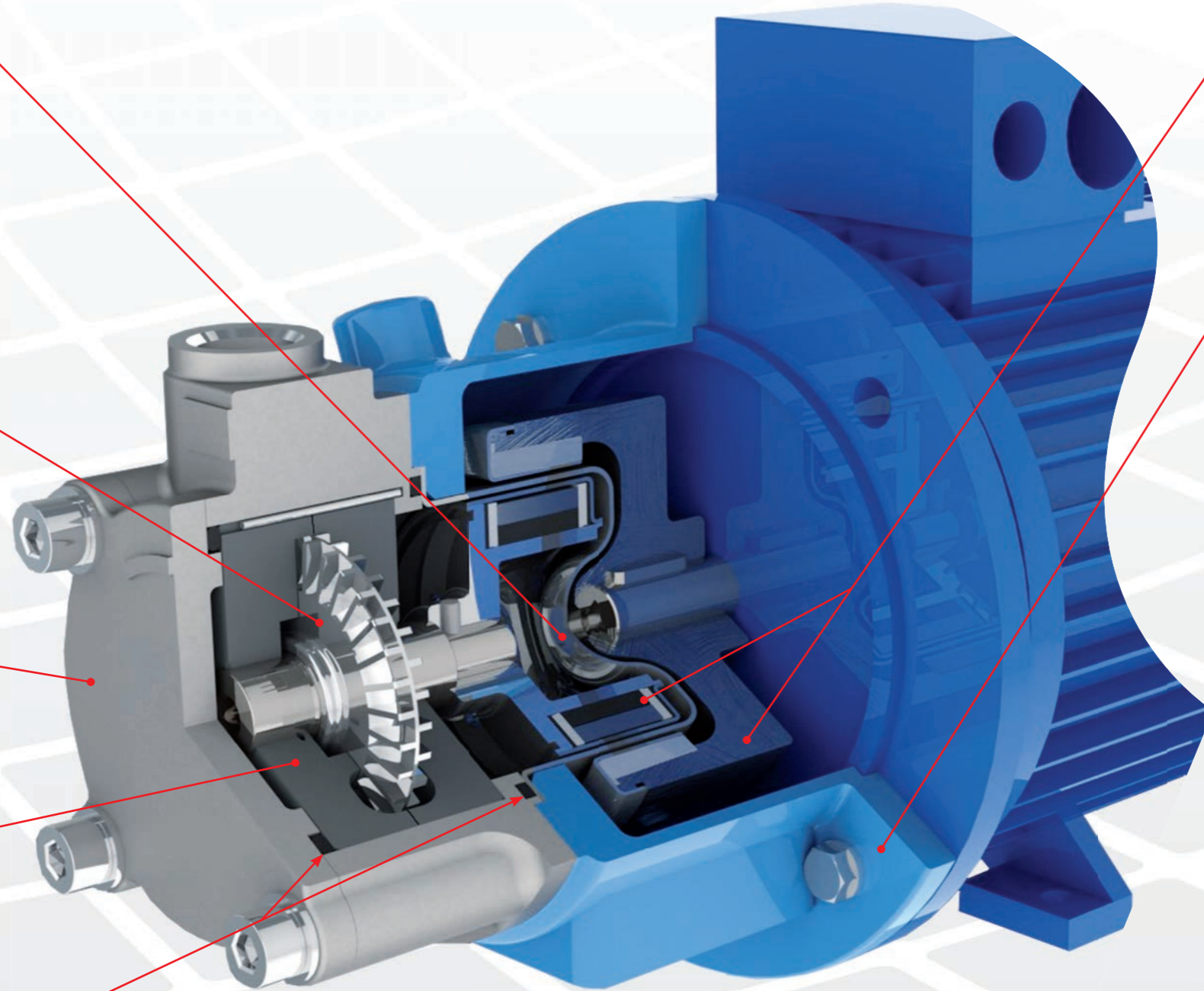

High power synchronous magnetic coupling designed by our Technical Office and with rare earth magnetic elements mechanically locked.

High temperature version available up to +662°F (+350°C).

Epoxy primer and polyacrylic enamel water-based painting for the best quality resistance linked to the environmental respect.

Quick maintenance:

repair the pump is very easy and fast, in three simple steps:

1/ Unscrew pump cover;



2/ Extract the cartridge, using one of the cover screw;



3/ Introduce the new cartridge and reassembly the pump.

