

Pump construction, operating limits and performances

Close-coupled drivers are conventional drivers mounted directly to pumps frame. No base, coupling or guards are required for this mounting style.

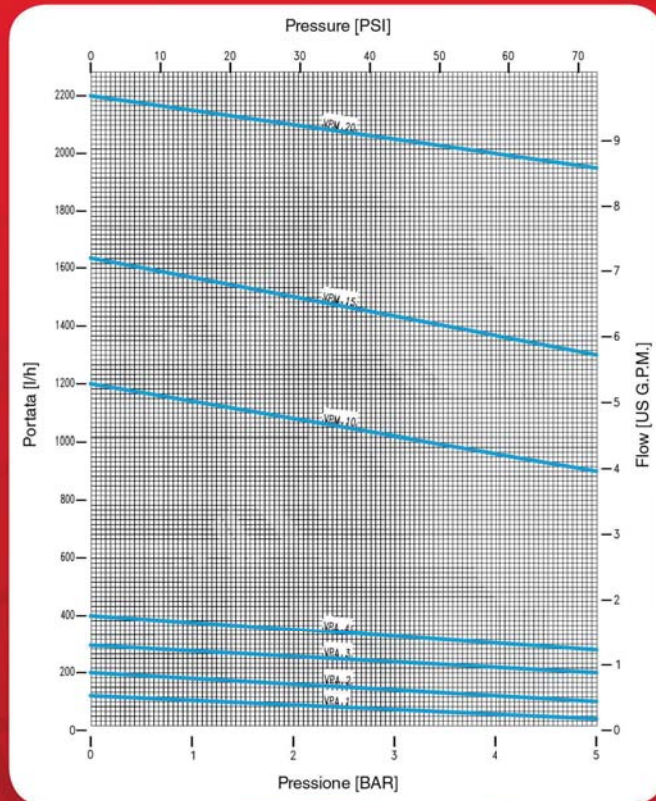

- Connections: Threaded BSP (GAS) & NPT, Universal Flange
- Max viscosity: 10000cSt
- Flow up: to 3000 l/h
- Head up: to 5 bar
- Temperature range: from -22 °F (-30 °C) to +194 °F (+90 °C)
- Electric motors: from 0,25 kW up to 2,2 kW
- Available ATEX II - / 3G cbk II CT5

HORIZONTAL, SEALLESS THERMOPLASTIC SLIDING VANE PUMP WITH PERMANENT MAGNET DRIVE SYSTEM, NO MECHANICAL SEAL

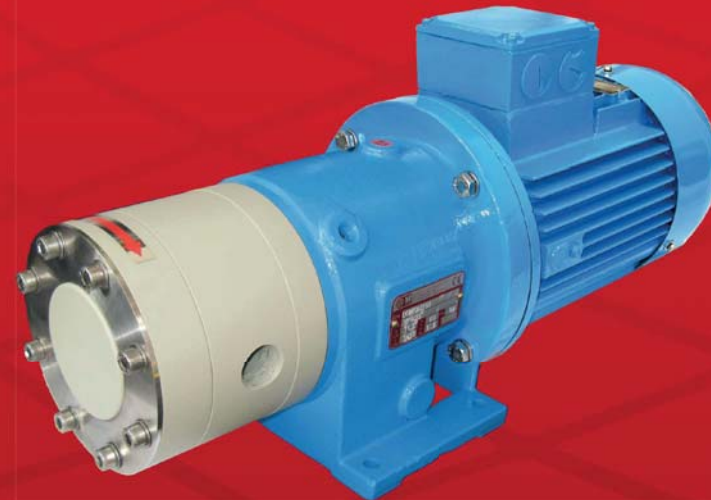

VP SERIES

Manufactured by:



A unit of
Mischiatti
GROUP

M PUMPS s.r.l. - Via dell'Artigianato, 120
45015 Corbola (Ro) - Italy - www.mpumps.it
Tel. +39 0426 346304 - Fax +39 0426 349126

For more information please contact:



Printed on 08-05-2014

VP Series

The separation of liquid chamber/atmosphere by means of an isolation shell is the best solution to pump aggressive chemical, high purity liquids and liquids difficult to seal.

The hermetic sealless is the best solution for the chemical and pharmaceutical industry.

A wide range of pumps covers the different performances.

Simple construction combine with important thickness that guarantee a long life against the corrosion.

PUMP DETAILS

Epoxy primer and polyacrylic enamel water-based painting for the best quality resistance linked to the environmental respect.

The sealing system with flat gaskets prevents from leaking in the atmosphere- different materials available:

- VITON®
- EPDM
- FEP
- GYLON®

Pump casing shall be one single piece, achieved from solid bar, made of very high thickness PP and PVDF to have a good mechanical resistance and a long life against the corrosion.

Quick change cartridge kit to guarantee an easy and fast maintenance. Materials available: cartridge phenolic graphite, rotor FCR-PVDF W/SIC bearings.

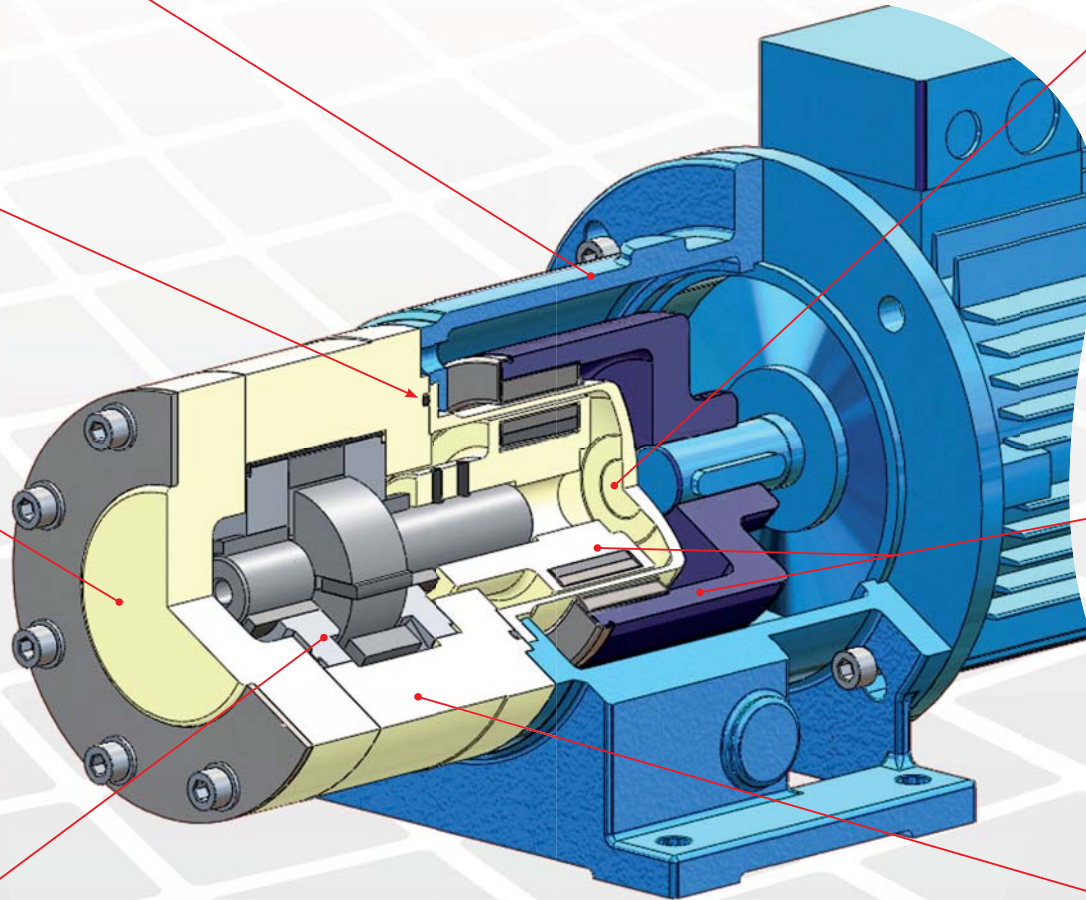

The rear shell is made of thermoplastic materials, zero magnetic losses, ellipsoidal profile, GFR-PP or CFR-PVDF.

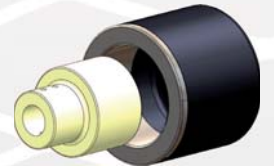

High power synchronous magnetic coupling designed by our Technical Office and with magnetic elements mechanically locked.



The pump casing is available in different connections: Threaded BSP(GAS) or NPT. Connections Universal Flanged that meet both DIN and ANSI 150#.