

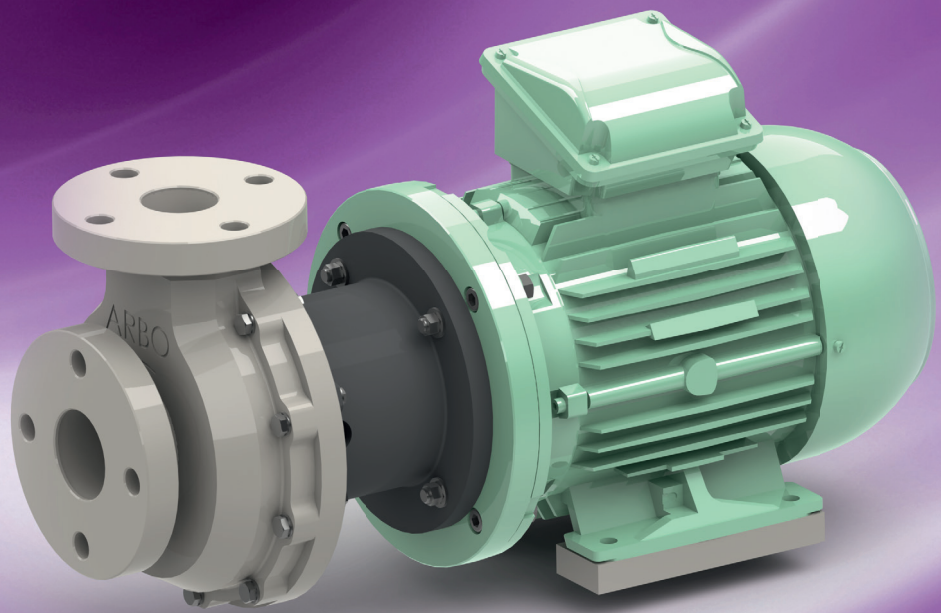

ARBO
THERMOPLASTIC
PUMPS
FILTERS



MODEL SEALPRO | WITH MECHANICAL SEAL

PG 1.1 CHEMICAL CENTRIFUGAL PUMPS



APPLICATIONS

For all transport or circulation duties of corrosive liquids, even high viscosity, with maximum efficiency.

This series of pumps is equipped with a state of the art semi-open impeller with pressure release.

It is fixed onto the shaft independent from the direction of rotation.

MATERIALS

Standard is the material PPH that covers a very wide range of duties.

For highly abrasive liquids (high % of solids), at special order, impellers or housing parts of High modulus HMPE are available.

For highly corrosive mixtures at higher temperatures even a pump housing entirely made of virgin PTFE is available.

TECHNICAL DETAILS PUMPS

Design pressure	PN6
Design standard (BG5)	DIN 24.256 - EN 22585 - ISO 2858
Max. system pressure	1.5 Bar with standard seal, 6 Bar optional
Min. flow	1 m ³ /h
Max. flow	50 m ³ /h
Max. head	45 m (60 Hz)
Max. viscosity	250 mPas
Max. solid size	2 mm

TECHNICAL DETAILS MOTORS

Standard	Three-phase, multivoltage, TEFC
High efficiency	IE2 efficiency level acc. IEC60034-30
Continuous duty	S1
Multi Voltage up to IEC100	220-240/380-415V 50 Hz // 440-460 V 60 Hz
Multi Voltage above IEC100	380-415V/ 660V 50 Hz // 440-460 V 60 Hz
Protection class	IP55 (IEC 34-5/ NEN-EN 60034-5)
Insulation Class	"F" ($\Delta T=80$ C);
Max. ambient temperature	-30 to 40°C, at 1000 m.a.s.l.
Max. relative humidity	< 95%

OPTIONAL AVAILABLE

Other voltages	f.i. 480 V/ 3 Ph/ 60 Hz
Other insulation	f.i. Tropicalized
PTC Thermistors	on windings
Water and/or dust protection:	IP56, IP65, IP66, IPW56, IPW65 or IPW66

CONSTRUCTION

MATERIALS	ABBREVIATION	T MIN. °C	T MAX. °C
Polypropylene	PP	0	80
High Modulus Polyethylene	HMPE	-50	80
Polyvinylidenfluoride	PVDF	-30	120
Polytetrafluorethene	PTFE	-30	120

ELASTOMERS

MATERIALS	ABBREVIATION	T MIN. °C	T MAX. °C
EPDM	E	-40	150
Viton	V	-25	220
Polytetrafluorethene	T	-190	260

ORDERING CODE (P.I.C.)

PUMP			MATERIALS						MOTOR					
Model	Discharge size (D)	Pump housing size	Material wetted parts	Impeller	Seal rotor	Seal stator	Double seal	Gaskets	Pole	Power	Voltage	Phase	Frequency	Atex
KR	15	85	PP	PP	TG	SI	2	E	2	0,18, 0,25	2	1	5	EX
	20	95	PVDF	PVDF	SI			V	4	0,37, 0,55	3	3	6	
	25	125	HMPE	HMPE				T		0,75, 1,1	4			
	32	160								1,5, 2,2	6			
	40									3,0, 4,0				
	50									5,5, 7,5				

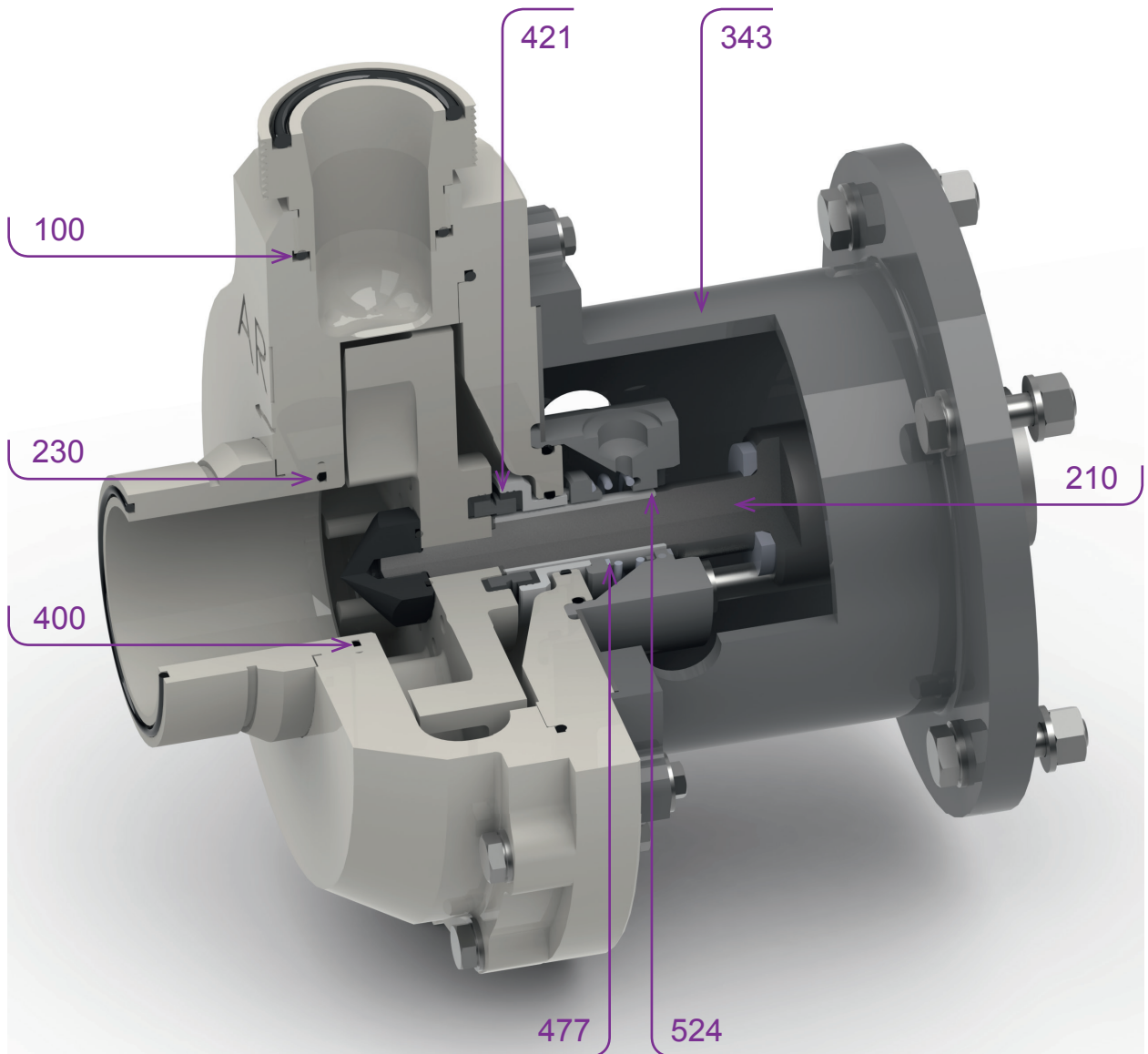

POS.	DESCRIPTION	STANDARD	ALTERNATIVE		
			HMPE	PVDF	PTFE
100	Housing parts	PPH	HMPE	PVDF	PTFE
210	Pump shaft	SS-316			
230	Impeller	PPH	HMPE	PVDF	PTFE
	Impeller type	Semi-open		Turbine	
343	Pump bracket	Plastic PPG			
400	Gaskets	EPDM		VITON	V/PTFE encapsulated
421	Type mechanical seal	Single inner		double with flush	
	Mechanical seal	PTFE-glas/SIC		SIC/SIC	
477	Pressure spring	Hast. C			
524	Shaft protecting sleeve	PTFE-glas			
800	Motor	2, 4 or 6 pole			
900	Fasteners	SS-316			

PERFORMANCE CURVES KR BG 2-3

PERFORMANCE CURVES 2-pole motors 50 Hz

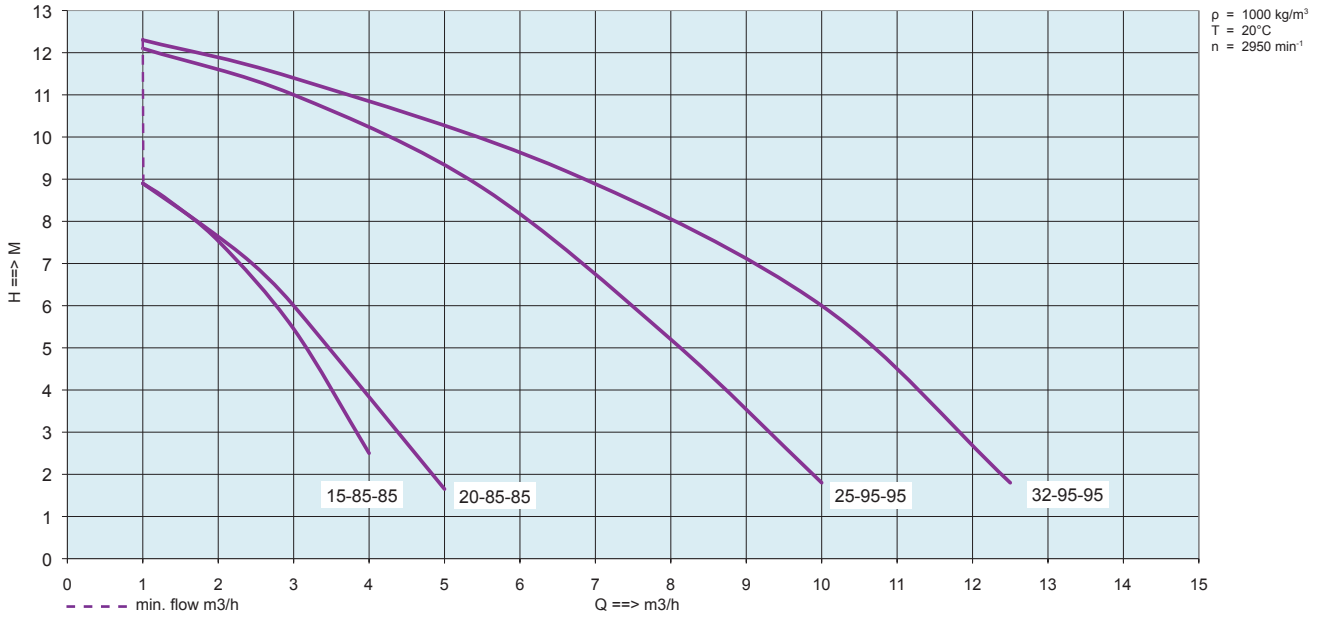

POWER CURVES 2-pole motors 50 Hz

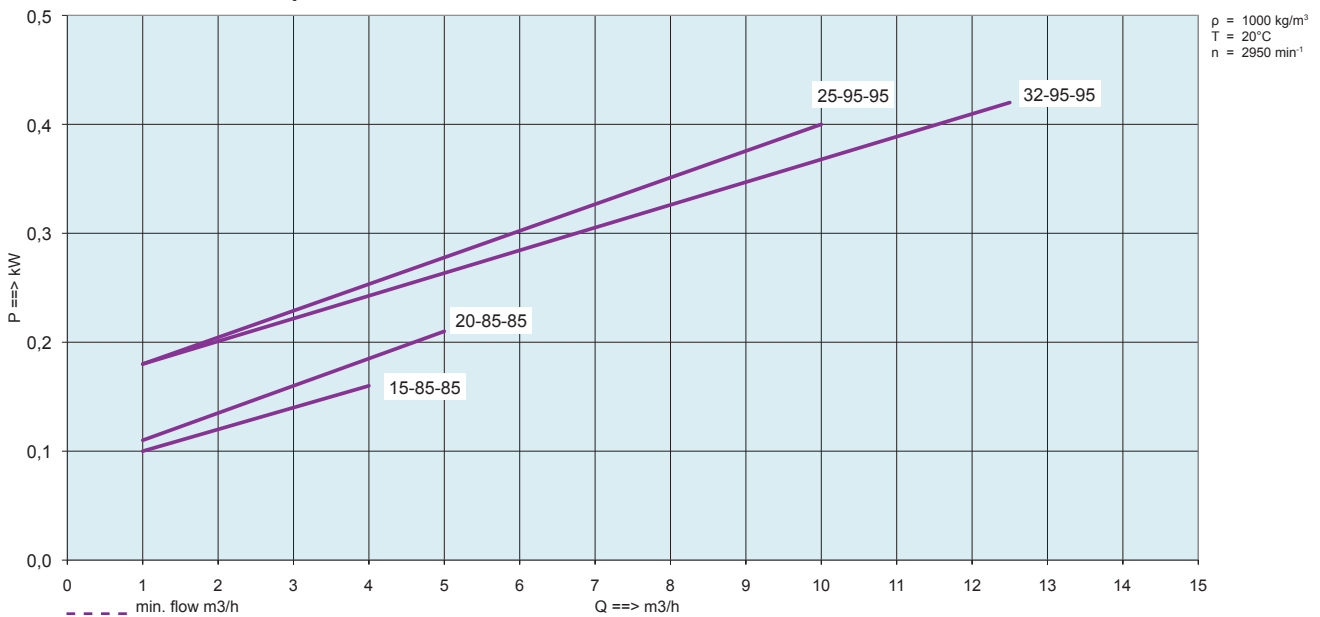

PERFORMANCE CURVES 2-pole motors 60 Hz

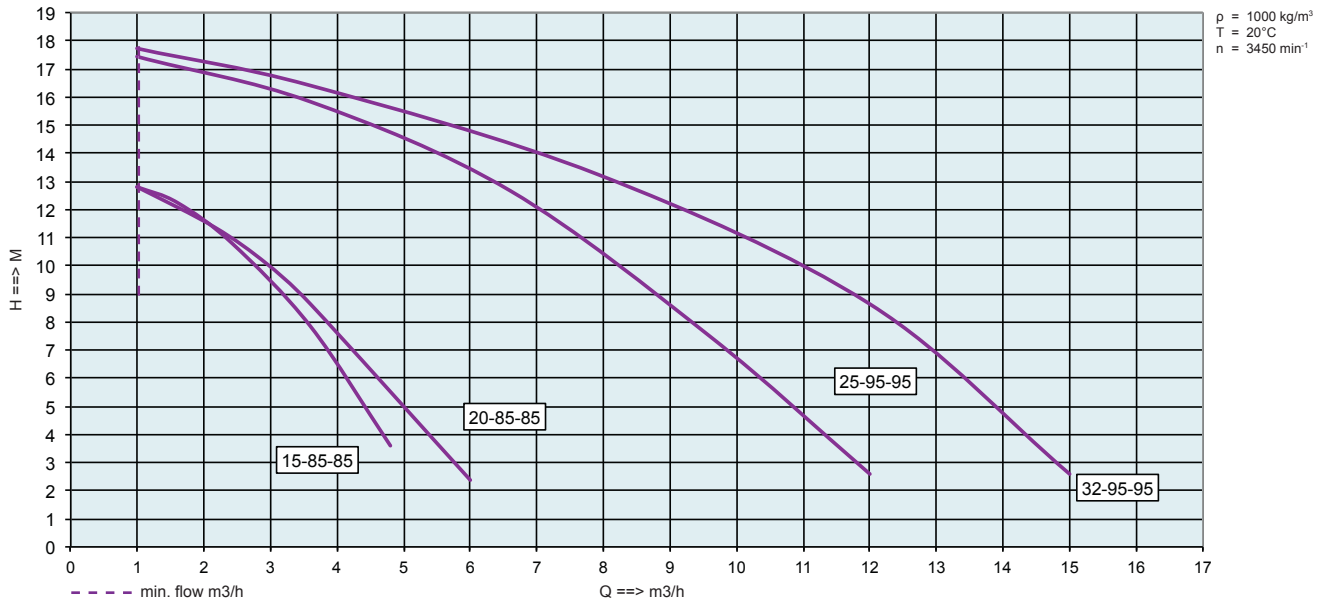

POWER CURVES 2-pole motors 60 Hz

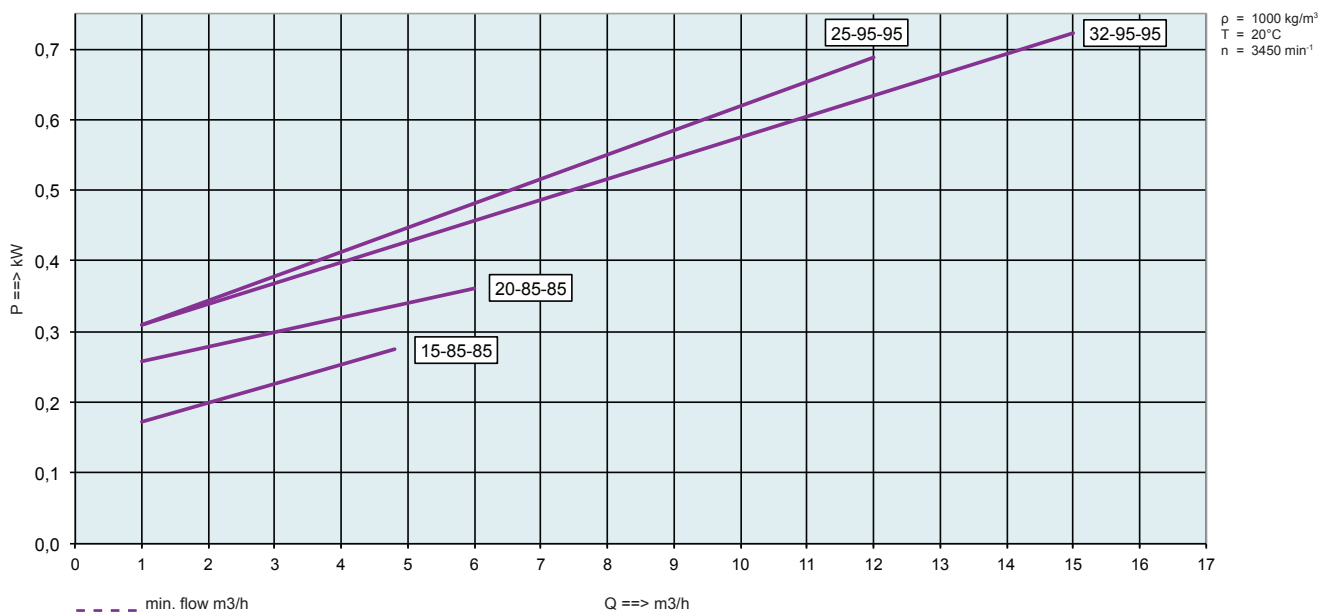

PERFORMANCE CURVES KR BG 4-5

PERFORMANCE CURVES 2-pole motors 50 Hz

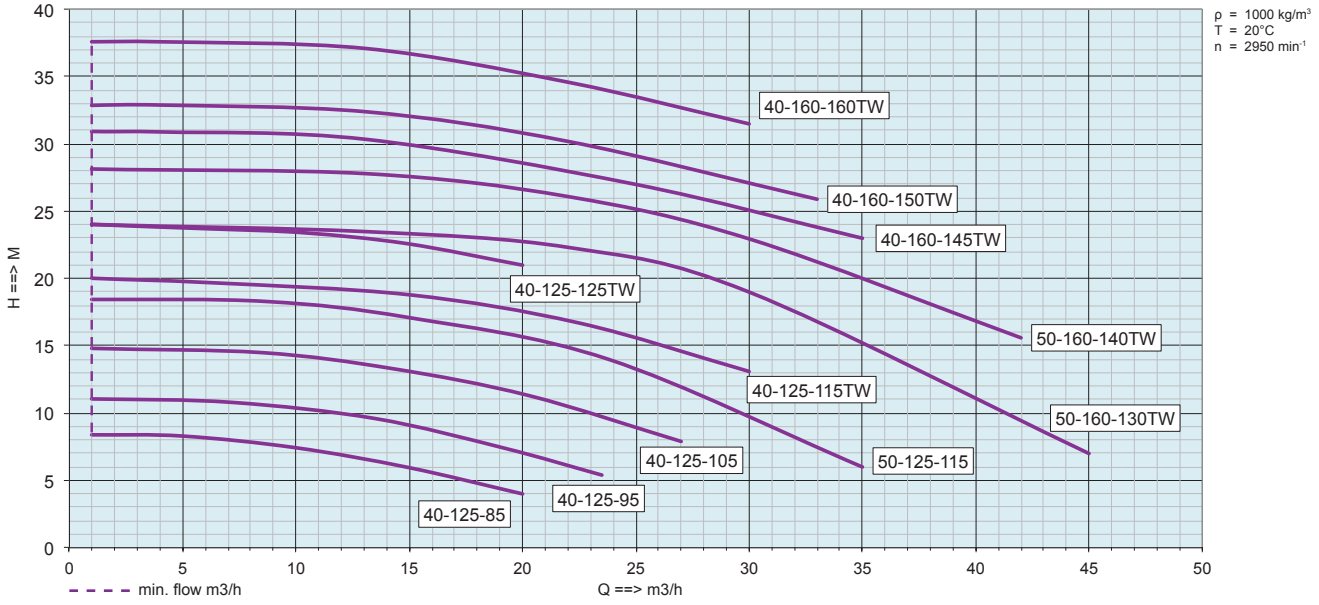

POWER CURVES 2-pole motors 50 Hz

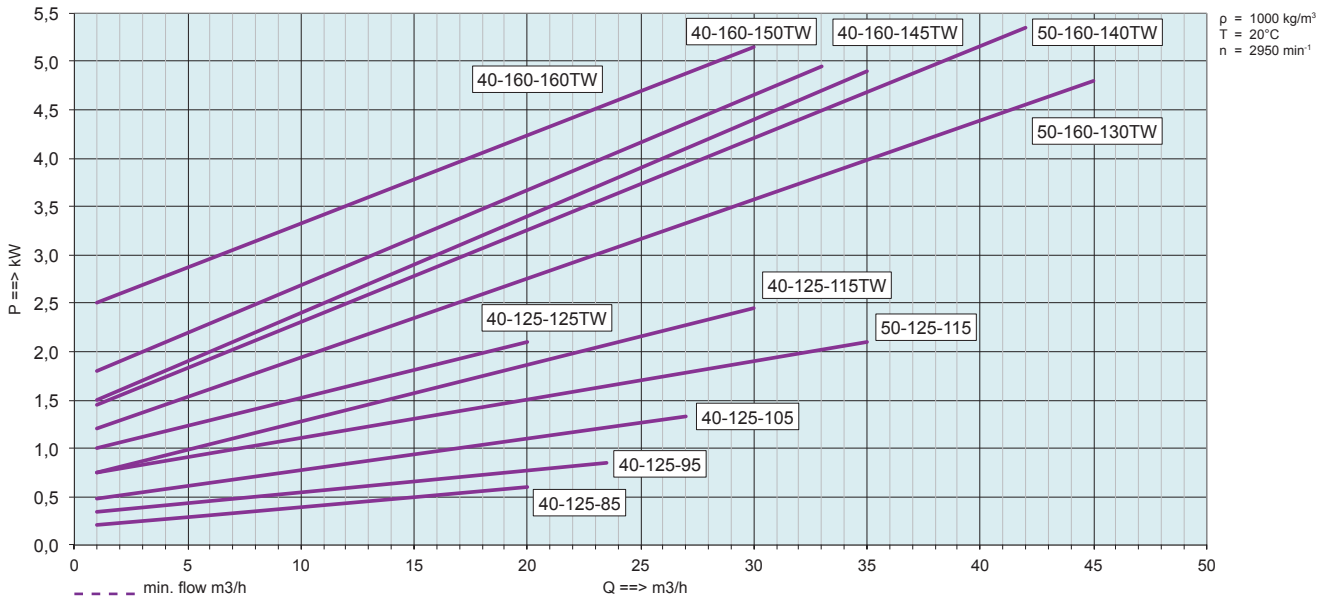

PERFORMANCE CURVES KR BG 4-5

PERFORMANCE CURVES 2-pole motors 60 Hz

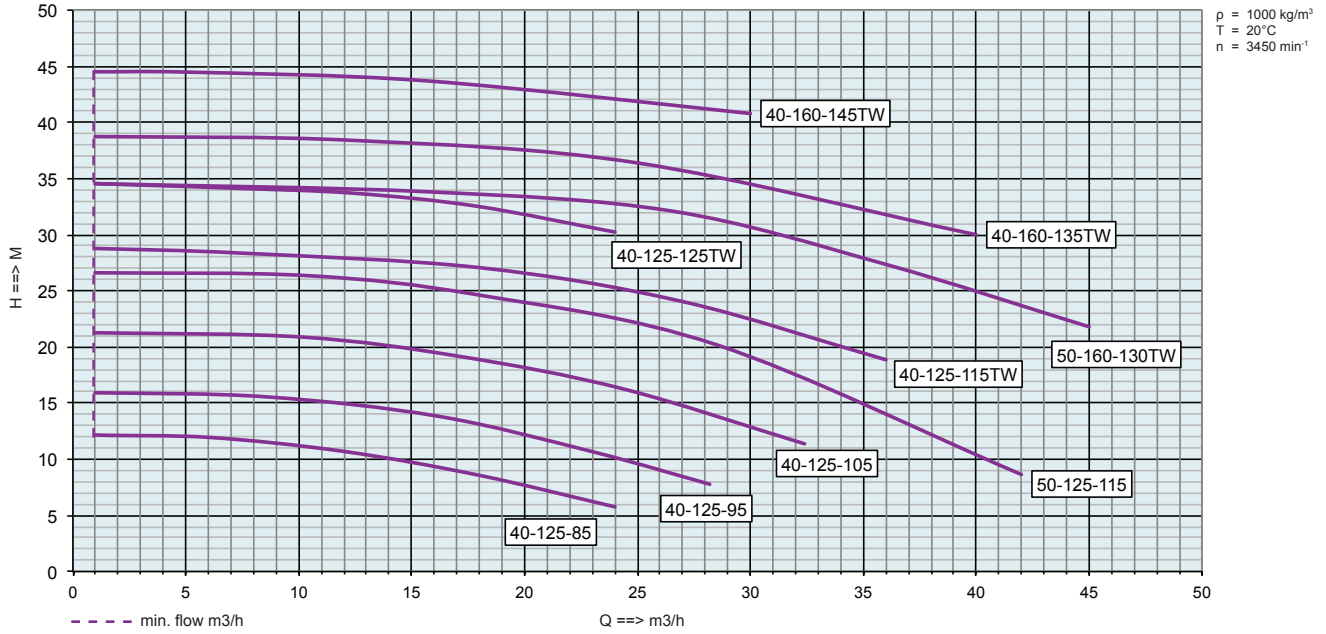

POWER CURVES 2-pole motors 60 Hz

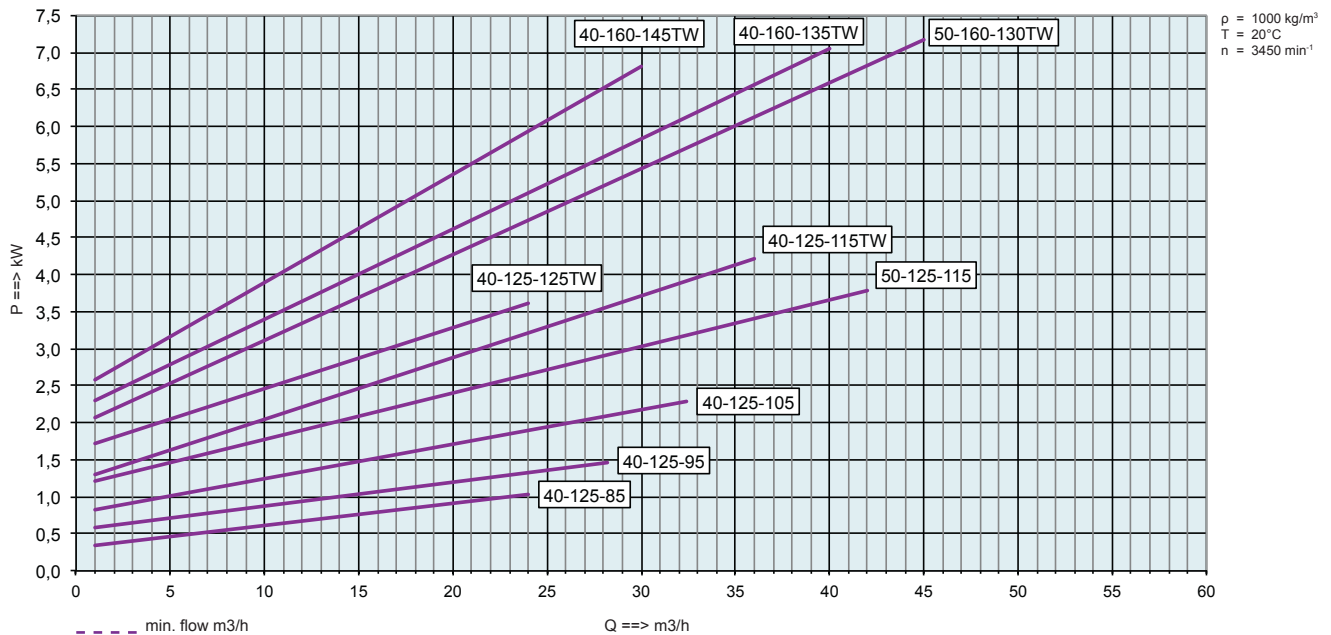

PERFORMANCE CURVES KR BG 3-5

PERFORMANCE CURVES 4-pole motors 50 Hz

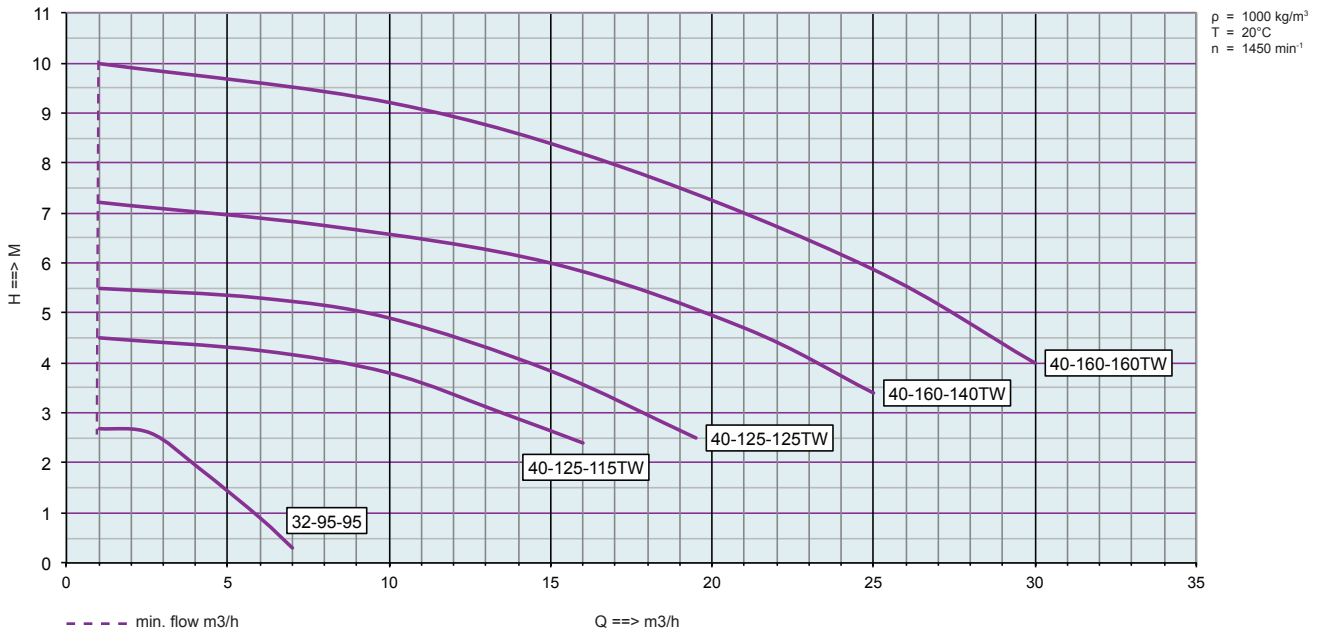

POWER CURVES 4-pole motors 50 Hz

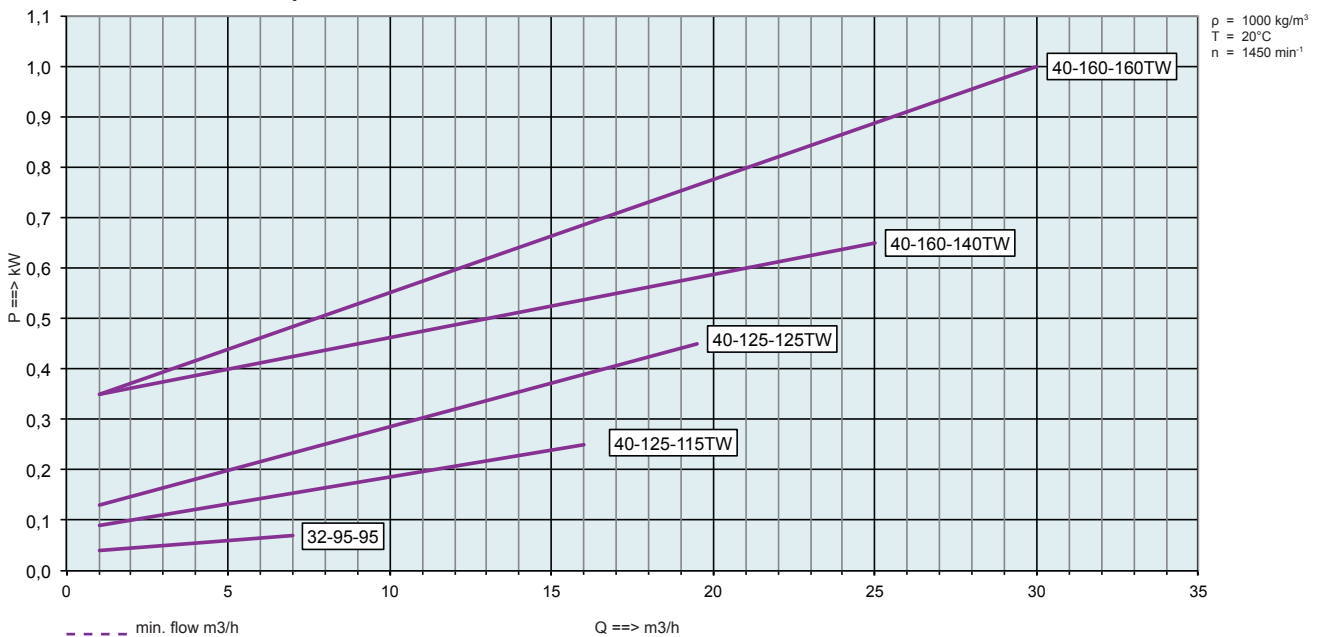

PERFORMANCE CURVES KR BG 3-5

PERFORMANCE CURVES 4-pole motors 60 Hz

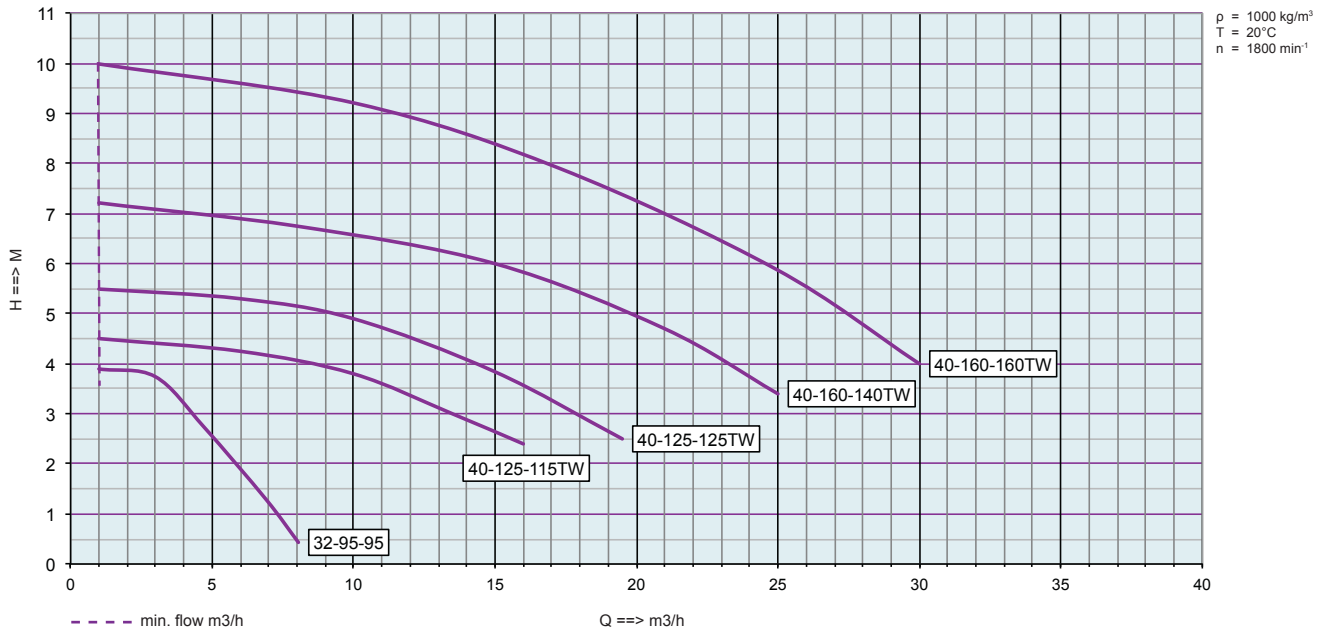

POWER CURVES 4-pole motors 60 Hz

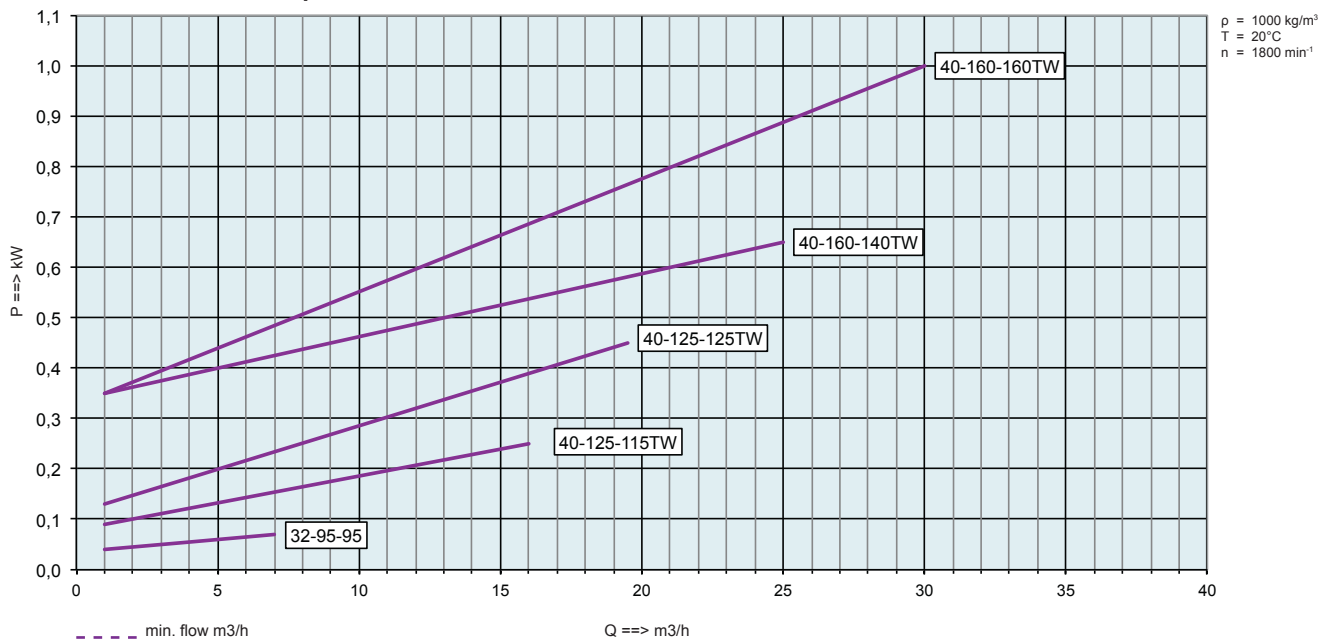

DIMENSIONS / WEIGHTS KR BG 2-4

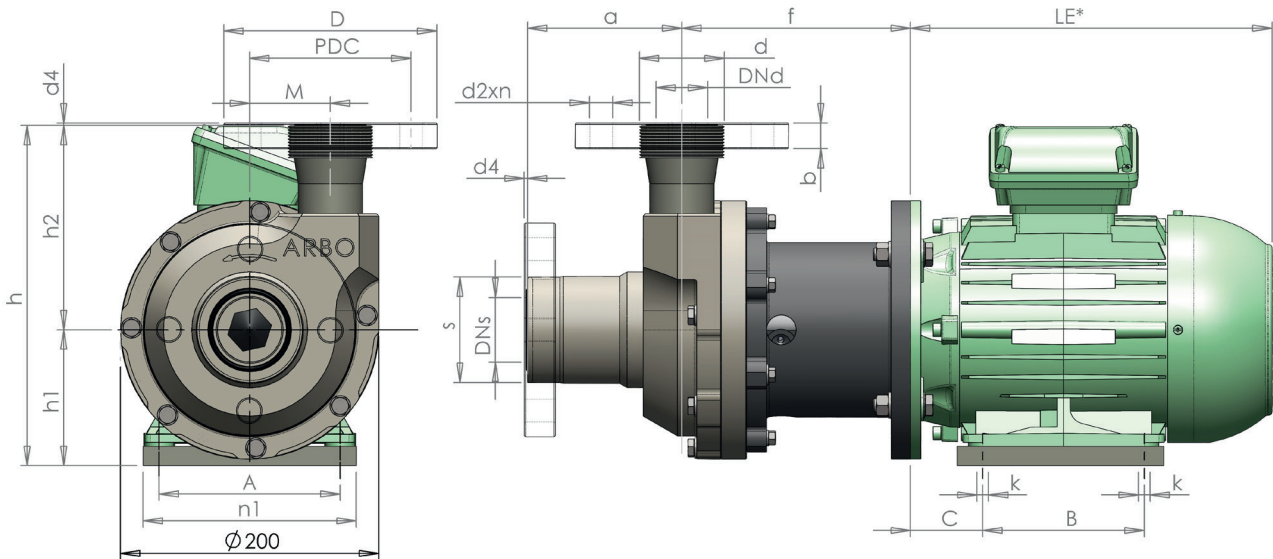

KR	MOTOR	DIMENSIONS PUMP WITHOUT MOTOR (MM) *										IMPELLER Ø MM		PUMP KG*		BOX SIZE	PACKAG.
		a	h1	h2	h	M	DNd	D**	DNs	S**	f	MIN.	MAX.	PP/PE	PVDF	CM	KG
15-85	63M	69	71	102	173	46	15	1"	15	1"	116,5	70	85	2,5	3	61x36x38	3
20-85	63M	66	71	124	195	46	20	1 1/4"	20	1 1/4"	116,5	70	85	2,5	3	61x36x38	3
25-95	71M	74	86	127	213	46	25	1 1/2"	25	1 1/2"	116,5	70	95	2,5	3	61x36x38	3
32-95	71M	74	86	127	213	46	32	2"	32	2"	116,5	70	95	2,5	3	61x36x38	3
40-40-125***	80M	120	105	158	263	63	40	2 1/4"	40	2 1/4"	177	85	125	5	6	81x42x42	6
40-125	80M	120	105	158	263	63	40	2 1/4"	50	2 3/4"	177	85	125	5	6	81x42x42	6
40-125	90S	120	105	158	263	63	40	2 1/4"	50	2 3/4"	177	85	125	5	6	81x42x42	6
40-125	90L	120	105	158	263	63	40	2 1/4"	50	2 3/4"	177	85	125	5	6	81x42x42	6
40-40-125***	90L	120	105	178	283	63	40	2 1/4"	40	2 1/4"	177	85	125	5	6	81x42x42	6
40-40-125***	100L	120	132	178	310	63	40	2 1/4"	40	2 1/4"	197	85	125	7	8	81x42x42	6
50-125	90S	120	105	160	265	63	50	2 3/4"	65	2 3/4"	177	85	125	5	6	81x42x42	6
50-125	90L	120	105	160	265	63	50	2 3/4"	65	2 3/4"	177	85	125	5	6	81x42x42	6
50-125	100L	120	132	160	292	63	50	2 3/4"	65	2 3/4"	197	85	125	7	8	81x42x42	6

* for motor dimensions and weights refer to motor specification sheet

** Male straight pipe thread

*** Connections interchangeable with old model KR-200 . See product information for details

FLANGE DIMENSIONS ACCORDING DIN2501 PN10

DN	G"	D	PDC	d4	b	d2Xn
15	1"	95	65	3	19	14x4
20	1 1/4"	105	75	3	19	
25	1 1/2"	115	85	3	19	
32	2"	140	100	3	19	18x4
40	2 1/4"	150	110	3	20	
50	2 3/4"	165	125	3	24	
65	2 3/4"	185	145	3	24	

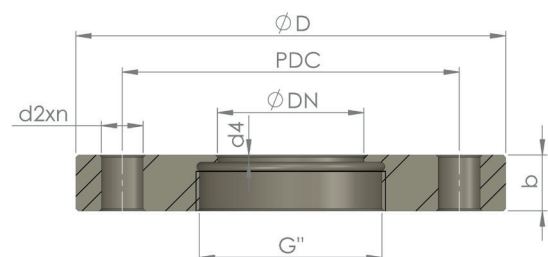

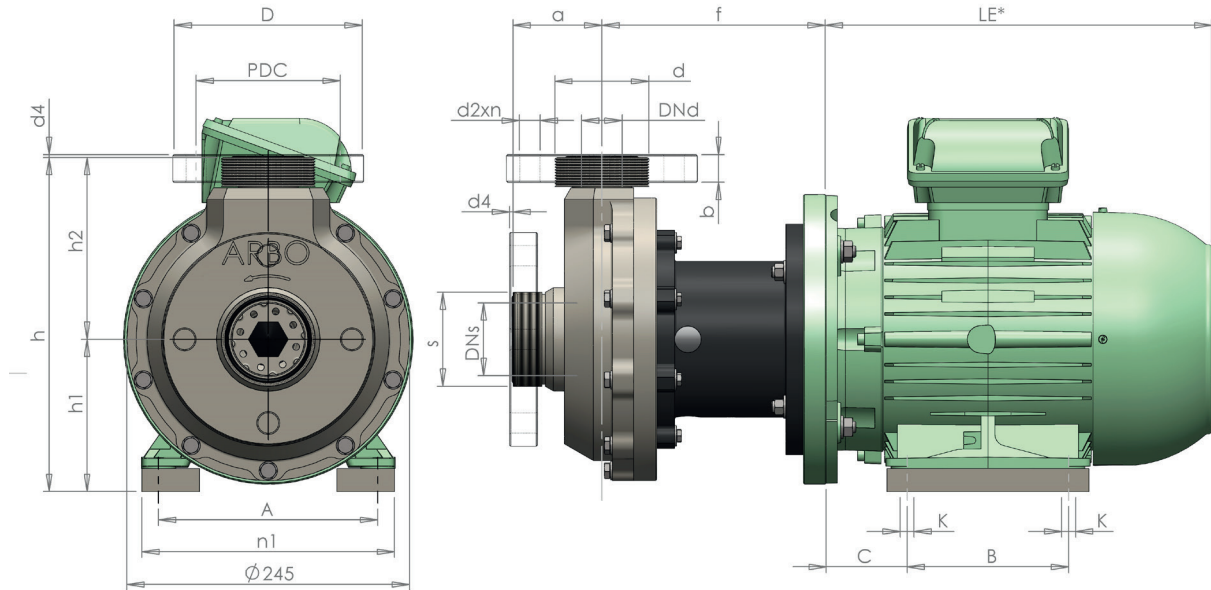
DIMENSIONS / WEIGHTS KR BG 5

KR	MOTOR	DIMENSIONS PUMP WITHOUT MOTOR (MM) *									IMPELLER Ø MM		WEIGHT KG*		PALLET SIZE	PACKAG.
		a	h1	h2	h	DNd	d**	DNs	s**	f	MIN.	MAX.	PP/PE	PVDF		
40-160	90S	77	132	158	290	40	2 1/4"	65	2 3/4"	175	100	160	7,5	9	80x60x50	6
40-160	90L	77	132	158	290	40	2 1/4"	65	2 3/4"	175	100	160	7,5	9	80x60x50	6
40-160	100L	77	132	158	290	40	2 1/4"	65	2 3/4"	195	100	160	9,5	11	80x60x50	6
40-160	112M	77	132	158	290	40	2 1/4"	65	2 3/4"	195	100	160	9,5	11	80x60x50	6
50-160	112M	77	132	158	290	50	2 3/4"	65	2 3/4"	195	100	160	9,5	11	80x60x50	6

* for motor dimensions and weights refer to motor specification sheet

** Male straight pipe thread

FLANGE DIMENSIONS ACCORDING DIN2501 PN10						
DN	G"	D	PDC	d4	b	d2xn
15	1"	95	65	3	19	14x4
20	1 1/4"	105	75	3	19	
25	1 1/2"	115	85	3	19	
32	2"	140	100	3	19	18x4
40	2 1/4"	150	110	3	20	
50	2 3/4"	165	125	3	24	
65	2 3/4"	185	145	3	24	

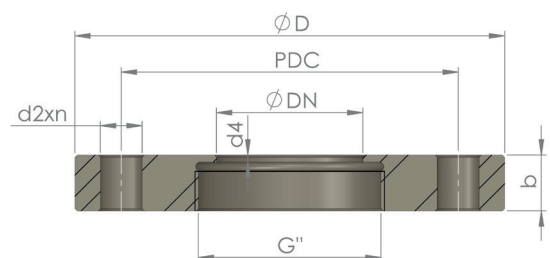

DIMENSIONS / WEIGHTS FOOT/FLANGE MOTOR IMB35 IM2001

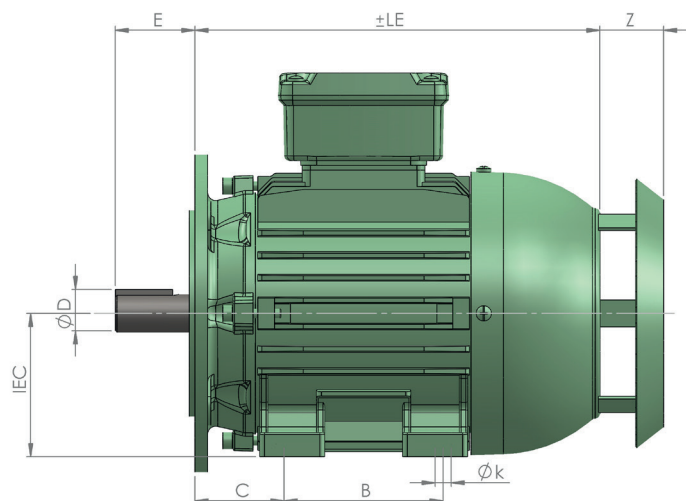

MOTOR	1450 min-1	WEIGHT	* In	2900 min-1	WEIGHT	* In	A	n1	B	C	k	D	E	LE	Z
IEC	kW	+/- KG	A	kW	+/- KG	A	(MM)	(MM)	(MM)	(MM)	(MM)	(MM)	(MM)	(MM)	(MM)
56	-	-	-	0,12	3,1	0,44	90	110	71	35	6	Ø9	20	178	-
63M	0,18	7	0,56	0,18	6,2	0,51	100	120	80	40	8	Ø11	23	195	35
63M	-	-	-	0,25	6,5	0,69	100	120	80	40	8	Ø11	23	195	35
71M	-	-	-	0,37	8,3	1,05	100	120	90	45	8	Ø14	30	220	40
71M	-	-	-	0,55	9,1	1,45	100	120	90	45	8	Ø14	30	220	40
80M	0,55	11	1,27	0,75	10	1,8	125	150	100	50	10	Ø19	40	240	40
80M	0,75	14	1,63	1,1	14	2,3	125	150	100	50	10	Ø19	40	240	40
90S	1,1	19	2,4	1,5	17,5	3,14	140	165	100	56	10	Ø24	50	255	40
90L	1,5	22	3,26	2,2	21	4,58	140	165	125	56	10	Ø24	50	280	40
100L	2,2	31	4,64	3	28	5,92	160	195	140	63	12	Ø28	60	320	40
112M	-	-	-	4	38	7,72	190	165	140	70	12	Ø28	60	365	40
112M	-	-	-	5,5	42	10,5	190	165	140	70	12	Ø28	60	365	40
132S	-	-	-	5,5	60	10,6	216	248	140	89	12	Ø38	60	375	45
132S	-	-	-	7,5	63	14,1	216	248	140	89	12	Ø38	60	375	45

DETAILS POS. 400 SINGLE MECHANICAL SEAL

EXPERIENCE

ARBO Pompen en Filters B.V. have a long history in seal designing. Since all our applications are of corrosive nature, we use high performance plastics or silicon carbide parts in the liquid zone exclusively.

STANDARD SEAL

ARBO's standard seal is a single, internal flushed rotating shaft seal. The beauty of this seal is that it is applicable to roughly 80% of all our heavy duty chemical applications.

The rotating seal ring is made of GR-PTFE or Silicon carbide and mounted onto the impeller. No seal component touches the sleeved pump shaft or pump housing. Therefore the wear parts are restricted to the seal rings and their elastomers.

Thanks to a smart internal circulation system, the seal rings that are both fully located inside the liquid zone, are continuously flushed with medium. This ensures sufficient cooling and cleaning of the liquid surfaces at all times.

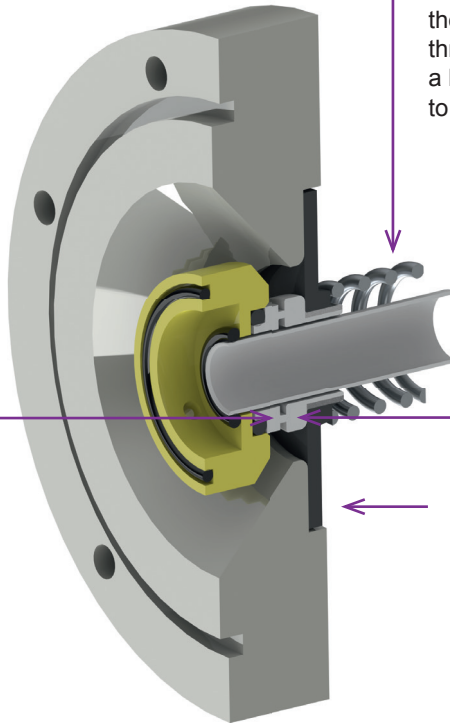

The pressure element ensures the optimum shaft sealing and is located outside the liquid zone. Therefore, contamination of the spring is impossible and the seal pressure is guaranteed throughout the seal life time; a huge advantage compared to conventional seals.

The static seal ring is mounted in a flexible diaphragm or O-ring that compensates eventual pressure waves.

CONSTRUCTION DATA MECHANICAL SEALS SEALPRO SERIES

SEAL TYPE	PUMP TYPES	PRINCIPLE	DESCRIPTION	MAX. HYDRO-STATIC PRESSURE BAR	MAX. OPERATING PRESSURE BAR	MAX. FLUSHING PRESSURE BAR	FLUSH L/H
				Standard		Standard	Standard
TGSI	15-85 - 32-95	single	internal Teflon/glass-Silicium carbide seal	1.5	2.0	-	-
SISI	15-85 - 32-95	single	internal Silicium carbide-Silicium carbide seal	1.5	2.5	-	-
SISI	40-125 - 50-125	single	internal Silicium carbide-Silicium carbide seal	1.5	2.5	-	-
SISI	40-125-TW - 50-125-TW	single	internal Silicium carbide-Silicium carbide seal	1.5	3.5	-	-
SISI	40-160-TW - 50-160-TW	single	internal Silicium carbide-Silicium carbide seal	1.5	5.0	-	-
SISI2*	40-125 50-160 (TW)	double	internal SISI seal/ external John Crane seal	3.0	5.0	3.0	50

For KR-BG4 and 5 the same seal principle is used as for the smaller models, however, the seal ring stator is not mounted in a diaphragm but in an O-ring. Thanks to this construction, these series may be used in low NPSHa situations.

Additionally, we have the possibility to install a double seal with flush.

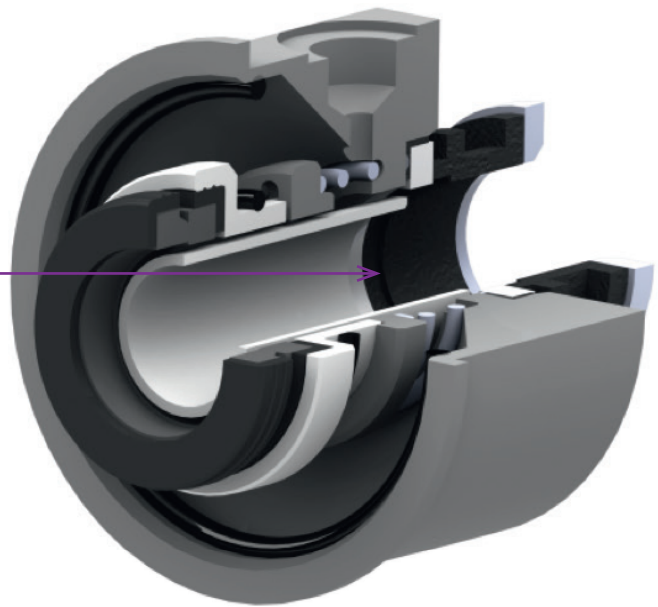

APPLICATIONS

Typical applications for the double seal are for media:

- that have a solid particle content above 10% by weight
- that may crystallise during operation or during stand still
- contain very tiny particles < 10 micron that may damage the single seal surfaces

It may be considered a low pressure version (< 1 Bar) and is used for all applications where a normal flooded suction is available without system pressures.

Again there are zero metal parts in the flush chamber and can therefore be considered 100% corrosion resistant; an advantage when wear in the front seal may contaminate the flushing liquid.

As flushing liquid, normal clear water may be used or an external flushing liquid unit can be delivered to provide one or more pumps in a closed circuit with only a very tiny water consumption

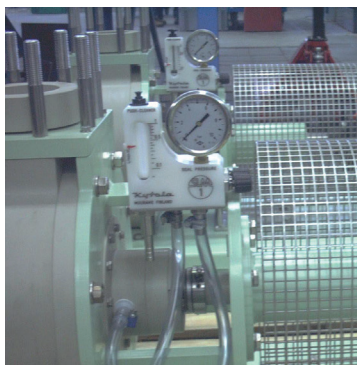
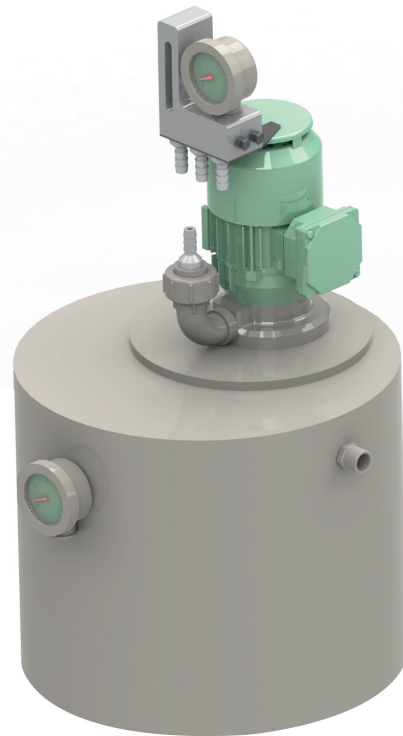

LIQUID SEAL MONITORS

In order to adjust flow rate and pressure, we advise to install Liquid seal monitors. These devices can be mounted to the pump units in order to adjust and monitor the correct flow and pressure of the flushing liquid.

WEIGHTS POS. 890 BASEMENTS ACC. DIN24.259 / KR-HD

For the close coupled pumps, that do not require precise alignment, ARBO offers lightweight and cost attractive baseplates.

The major advantage of using a baseplate are that pump and/or motor foot is not in direct contact with the floor. Especially on factory floors there may be chemical spills that will normally cause corrosion to the metal parts.

By placing a corrosion resistant baseplate, the setup will last longer, look better and eventually save cost!

It is also a professional method to combine a priming vessel or suction strainer together with a pump to one ready to install set.

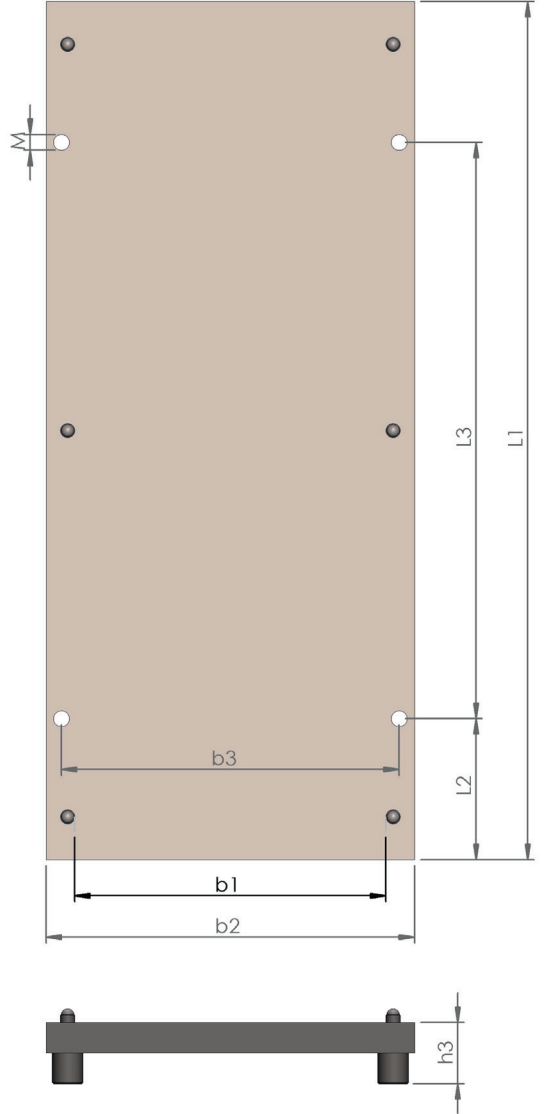
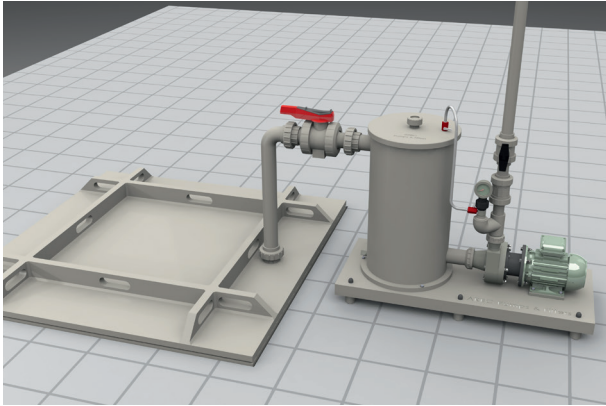

BASEPLATE SIZES (MM) ACCORDING DIN24 259						
NR.	1	3	4	6	7	8
L 1	560	900	1000	1250	1400	1600
L 2	100	150	170	205	230	270
L 3	340	600	660	840	940	1060
b 1 max.	170	300	340	430	480	530
b 2	260	390	450	540	610	660
b 3	220	350	400	490	550	600
h 3	75	75	90	90	100	100
M	M16	M16	M20	M20	M24	M24
KG	1,8	2,9	2,0	2,3	2,5	2,9



ARBO

THERMOPLASTIC
PUMPS
FILTERS



WHY ARBO PUMPS | FILTERS?

ARBO Pumps | Filters can be characterized by reliability, flexibility, quality and sustainability. Thanks to the smart design, the lower energy consumption and maintenance costs, your investment urn back time is very short time!

MARKETS

- Hot tub galvanising
- Anodising
- Plating
- Production of micro-electronic and semi-conductors
- Waste water treatment
- Fish farms
- Sea water aquaria
- Desalination plants
- Industrial and agricultural scrubbers
- etc.



**ARBO
POMPEN EN FILTERS B.V.**

Leemdijk 2
9422 CL SMILDE
THE NETHERLANDS

T : +31 (0) 592 430 310

E : info@arbo-pumps.com
I : www.arbo-pumps.com

DISTRIBUTED BY: