

# Operating Instructions



## TL3800 3/8" Tie-Lok Hand Tool

This tool is designed for use with Band-It 3/8" wide Stainless Steel Tie-Lok Ties

A) Form a clamp by threading the end of the tie through the buckle, with the gap in the buckle facing up. Tighten the band by hand to maintain a minimum clamp tail of 3 inches to ensure the tip of the clamp tail can be inserted into the winding mandrel.

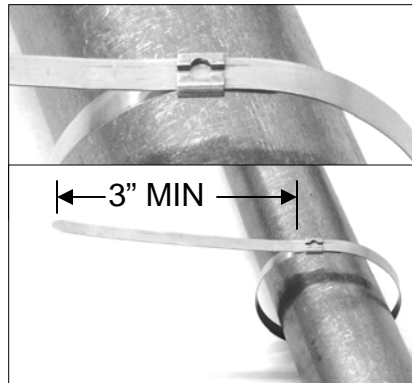

B) Holding the cut-off handle against the bottom of the main handle, insert the tail of the clamp into the head of tool and slide into slot of winding mandrel. Position the ratchet pawl so that it engages fully with the ratchet gear.

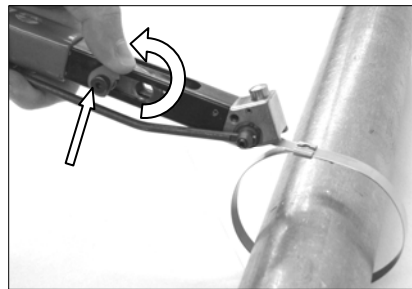

C) Tension the clamp with forward strokes of ratchet handle. When the desired tension is reached or the ratchet gear makes contact with the stop pin, release the ratchet handle. Tension will be maintained by the ratchet pawl.

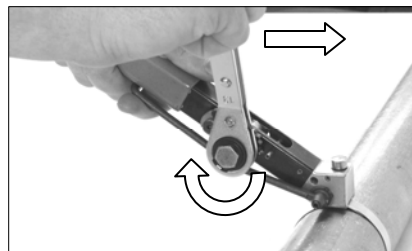

D) Lock the band clamp by holding the tool body in one hand while hitting the punch with a mallet to form a dimple in the center of the buckle. The head of the punch will bottom against the top of the tool head.

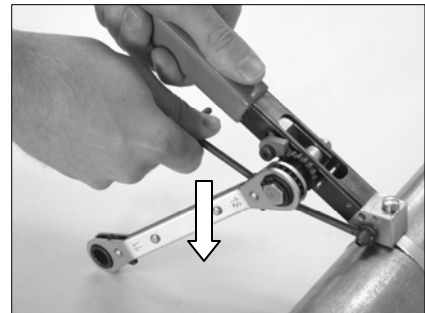

E) After the lock is secured, cut off the excess band tail by firmly pushing the cut-off handle downward.

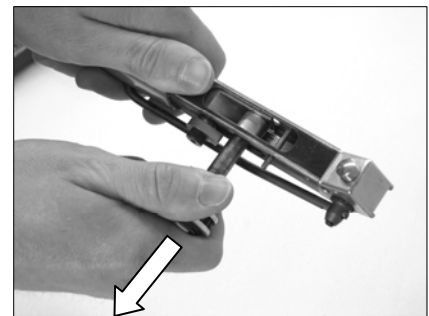

F) Carefully remove the excess band tail by removing the winding mandrel and ratchet from the tool body.



G) Example of finished clamp.

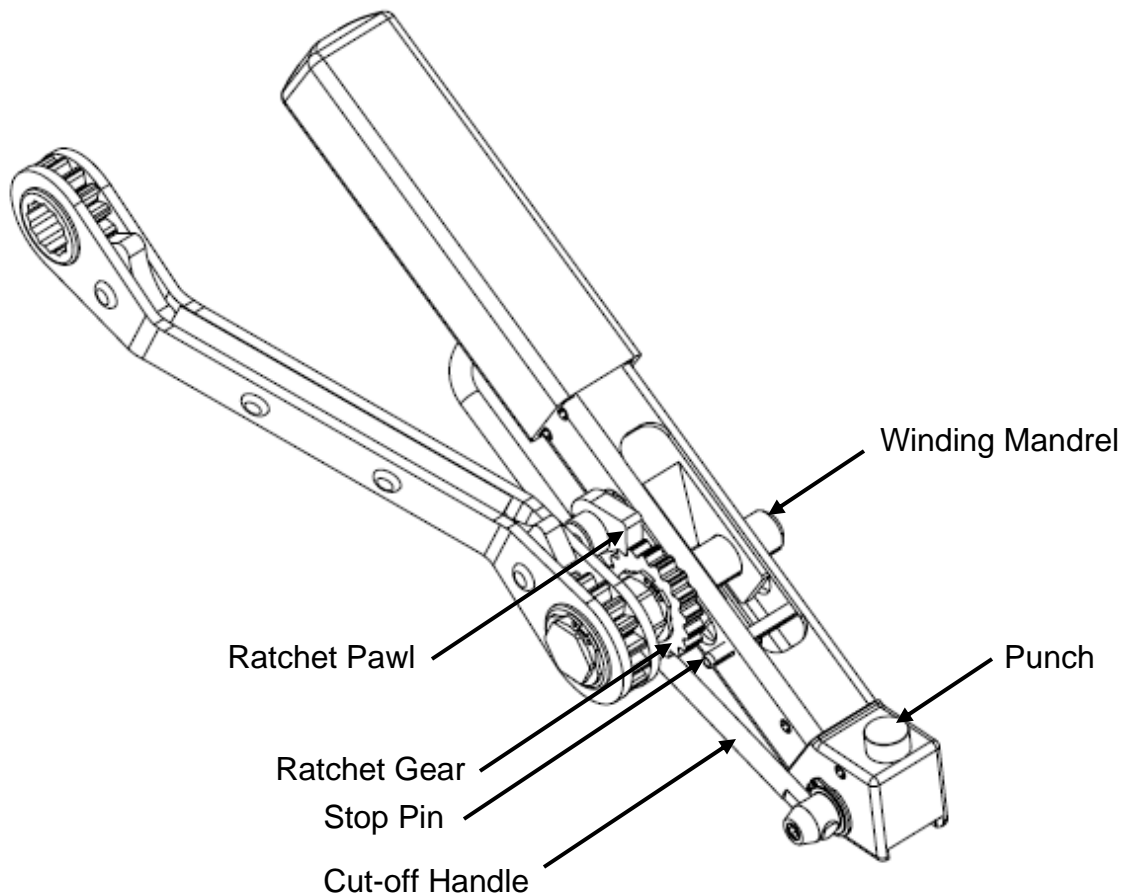

Refer to website for warranty information: <http://www.band-it-idex.com/warranty.html>