

**Table of Contents**

<b><u>Page</u></b>	<b><u>Information</u></b>
2	Safety Guidelines and Warranty
3	Tool Overview and Installation
4	Air System Requirements
5	Setting Controls
6	Installing Center Punch Clamps
7	Trouble Shooting Guide
8	Preventative Maintenance
9	Center Punch Head Information
10	Gripper Assembly
11	Replacement/Service Parts Identification
12	Air Connection Diagram
13	Factory Services

## Warranty and Safety



**BAND-IT**<sup>®</sup>  
A UNIT OF IDEX CORPORATION

## SM1700 Pneumatic Center Punch Tool

### Warranty:

For Warranty information visit the following URL

[www.BAND-IT-IDEX.com/Warranty.html](http://www.BAND-IT-IDEX.com/Warranty.html)

### Safety Guidelines:

- Read this manual and become familiar with the tool before installing any clamps.
- Protective eyewear should be worn when connecting and disconnecting the tool to compressed air sources and during operation.
- Wear appropriate gloves for handling steel while operating this tool, applying steel clamps and removing the scrap clamp tail.
- Tool should be firmly mounted before installing clamps.
- Clamp tensioning or clamp tail retrieval can be immediately stopped by releasing pressure from the foot pedal.
- When applying clamps, care should be taken to insure fingers and loose clothing are not in the way of the clamp being applied.
- Never attempt to clamp objects which have the potential to burst, shatter or otherwise cause bodily harm.
- Disconnect air supply prior to maintenance and disassembly of tool components.

### Important advice and warning to user, Read before applying clamps:

*The Center Punch type clamp's lock and cut-off is achieved using considerable impact. This may cause damage to the object being clamped.*

Remember that a tighter clamp keeps the fitting more secure, but excess tension could damage the hose or fitting. Fitting stem must have prominent barbs for proper retention inside the hose, but barbs must not be sharp to prevent cutting into the hose. Hose, fitting and clamps must be compatible with each other and the intended working environment. If in doubt, consult the hose or fitting manufacturer or call BAND-IT.

Clamping objects other than hose require similar precautions.

**CAUTION:** Improperly tightened clamps may result in dangerous hose assemblies, which could cause injuries or property damage.

**CAUTION:** Abuse or use of hose outside the manufacturer's recommended conditions may cause it to quickly deteriorate and become a safety hazard. This could result in serious injury or property damage. Inspect and test hose assemblies frequently. Repair or replace at the slightest sign of damage or deterioration.



### Tool Overview:

- The SM1700 has been designed to automatically tension, lock and cut-off scrap tails of CP style clamps. Type 201 Stainless Steel and Galvanized Carbon Steel, 5/8" wide CP style clamps can be easily installed on hose assemblies or objects chosen by the operator.
- The SM1700 will sense when the desired clamp tail tension is achieved and automatically switch to finalize the clamp. The completion of each clamp includes setting the lock while simultaneously cutting off the excess clamp tail without requiring an assembly roll-up action.
- **Operating tip:** Choose a clamp diameter close to the size of the diameter of the object being clamped. An oversized clamp may cause the End-of-Stroke safety switch to activate and prevent finalizing the clamp with a lock and cut-off (see page 6, #6 and page 7, #4).
- The SM1700 directs compressed air through a foot pedal control to cycle the tool and complete the installation of BAND-IT Center Punch Clamps. The foot pedal has a dual action, forward (toe) and reverse (heel). During normal operation, the operator should fully depress the foot pedal forward (toe), not removing this pedal pressure until the cycle has completed and clamp tail is ready to be removed from the tool.
- Upon completion of the tension, lock and cut-off cycle, the operator should depress the heel end of the pedal and remove the scrap clamp tail from the CP head.
- **Operating tip:** Operation can be stopped at any time by removing the operator's foot completely from the foot pedal control.

### Tool Installation:

1. Recommended work bench height is 34" – 40". This height is suggested as the optimum range for operator comfort and safety during typical clamp applications. Locate the tool on a solid surface making sure of ample clearance on either side for handling hose assemblies of various lengths.
2. The air tool must be firmly secured as close to the front edge of the work bench as possible. This will reduce interference of hose assemblies during clamp application. Install tool using 5/16" diameter fastening hardware (not supplied with tool).
3. Use of the SM1700 without properly maintained filtration and lubrication will void the warranty. See page 4 for additional information on air supply requirements.



**Important:** For proper tool performance, follow air requirements for SM1700:

Line Pressure – 70 psi minimum, 120 psi maximum (4.9 – 8.4 kg/cm<sup>2</sup>, 483 – 827 kPa)

Volume - 3-5 CFM

Air Delivery system - 1/4" minimum diameter air line with a 1/4" N.P.T. connection.

Filtration – Follow typical filtration requirements of air operated equipment. The BAND-IT supplied system includes a filter and lubricator.

Lubrication - Use DTE 24 hydraulic oil (BAND-IT part # S31589), oil drip-rate is verified by cycling the machine. If one drop falls in sight glass within 10-25 cycles, the lubricator is correctly adjusted. Excess oil will not benefit tool life and may lead to blockage of air mufflers and a dirty environment.

Solvents - Liquids such as solvents or cleaners should never be added to the air system through air lines.

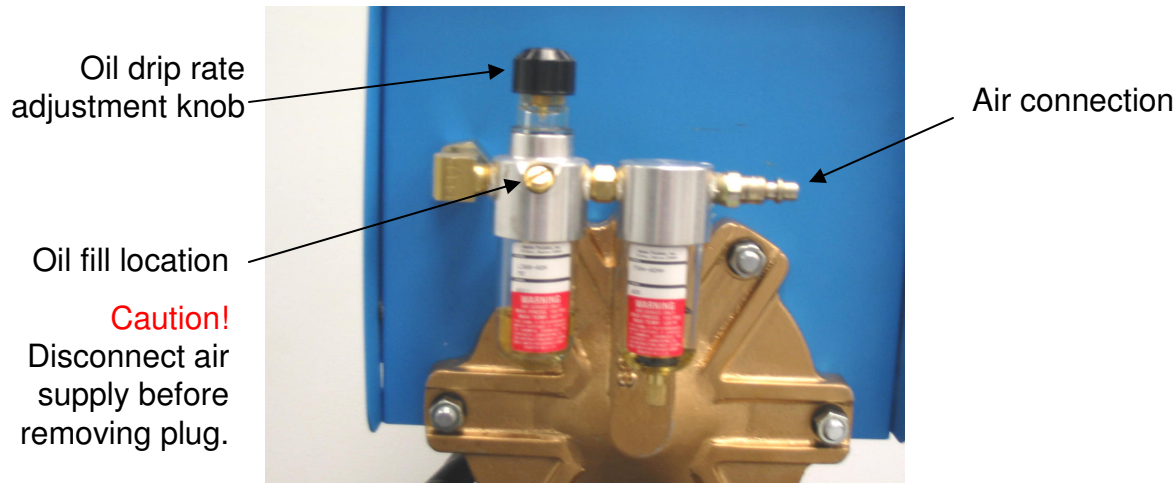

View of the back side of the SM1700 showing the supplemental (included) filtering and lubrication system as well as the 1/4" N.P.T. air connection with a typical quick connect coupling.

**Warning:** The lubricator should be refilled with DTE 24 hydraulic oil only. The use of other oils may cause damage to the system.

## Setting Controls



**BAND-IT**<sup>®</sup>  
A UNIT OF IDEX CORPORATION

## SM1700 Pneumatic Center Punch Tool



Air pressure setting can be made using the regulators and gauges on face of the tool.



End-of-Stroke Indicates the desired clamp tension and cut-off has not occurred. Also shown is speed control with red lock ring.

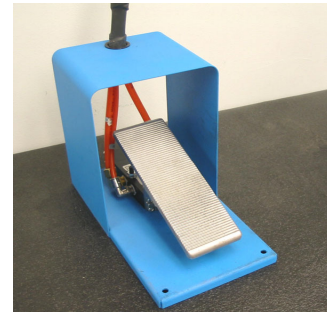

Dual function foot control valve. Pressing forward activates clamp installation. Heel action activates tail return and prepares for next clamp.

**Rule: Always approach pull-up pressure setting from below and hold pressure setting from above the recommended value.**

1. Set the speed control to blue for all BAND-IT 5/8" wide Center Punch Clamps.
2. Set pull-up pressure: pull knob and turn clockwise to reach pull-up pressure. Approach pressure setting from below by increasing pressure. Suggested settings are listed below. Adjust as necessary for the clamping application. Caution! Do not adjust below 20 psi or head misfires may occur.  
35 PSI for 5/8" wide GCS clamps  
40 PSI for 5/8" wide SS clamps
3. Set holding pressure to 8 – 12 PSI. With foot pedal at rest, increase pressure until it is above recommended setting. Slowly lower pressure by turning knob counterclockwise to recommended setting.
4. Check pressure setting by cycling tool until holding pressure gauge stops.
5. With foot pedal still depressed, verify all settings and adjust if necessary.
6. Reset tool by depressing heel end of foot pedal. Remove foot.
7. Repeat steps 2, 3, 4, and 5. At pressure kick down, verify all settings and adjust if necessary.

**Caution:** Always allow air to completely exhaust after resetting tool and before pull-up. Failure to let air completely exhaust may result in clamps not pulling up tight.

## Installing Clamps



**BAND-IT**<sup>®</sup>  
A UNIT OF IDEX CORPORATION

## SM1700 Pneumatic Center Punch Tool

### Installing BAND-IT Center Punch Clamps:

- 1) Choose correct material type and diameter clamp to best satisfy the needs of the application.
- 2) Installation of two BAND-IT Center Punch Clamps per hose end is suggested. Place clamps over hose, then install fitting. Note the location of the fitting's hose barbs in order to locate clamps between barbs for maximum fitting retention. The buckles of each clamp should be located opposite of each other to increase resistance to leak paths.
- 3) Insert the clamp tail fully into the nose of the tool with the buckle on top. Position the clamp in the desired location on hose.
- 4) Small diameter hose assemblies (less than approximately 2") will receive a considerable impact during the lock and clamp tail cut-off process. For stiff hoses, it will help to lessen the impact by holding these small hose assemblies with only one hand on the hose end of the assembly (do not hold the end of the assembly with the fitting). This will soften the jolt and allow the assembly to swing down to absorb the impact. For flat or thin-wall hose, inserting an easy to hold object that will not harm the fitting into the end of the fitting for additional support may help.

*Keep hands away from clamp being applied!*

- 5) Depress the toe end of the foot pedal control to tension clamp, keep the toe end down until the clamp has been fully tensioned, locked and cut-off is complete.
- 6) If the cylinder reaches the end of its stroke during tension, the cutoff cylinder will be disabled and the end-of-stroke indicator will turn red. Pull firmly on the clamp while reversing the cylinder. Remove the clamp. Before regripping, cut off any tail greater than 4 inches. Start the tension cycle over at step 3.
- 7) Depress the heel end of the foot control and retrieve the clamp tail from the tool head.

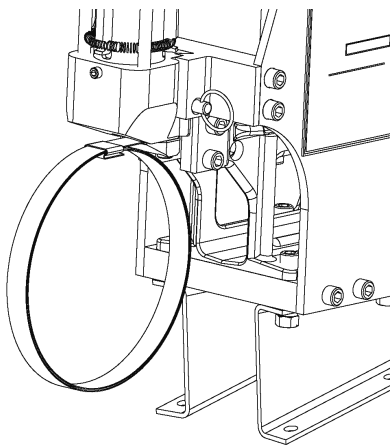

Clamp tail inserted into blade assembly

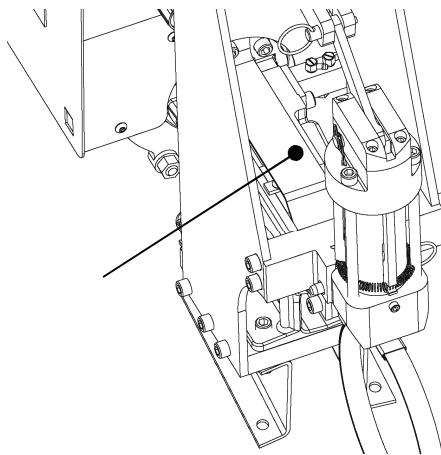

Guard/tail depressor provides downward pressure on scrap clamp tail.

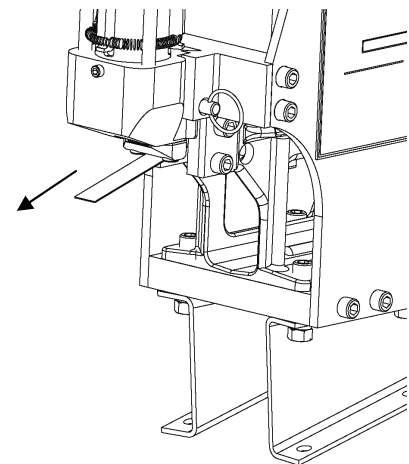

Clamp tail in normal return position. Pull tail from tool.

# Trouble Shooting Guide



**BAND-IT**<sup>®</sup>  
A UNIT OF IDEX CORPORATION

# SM1700 Pneumatic Center Punch Tool

Problem	Probable Cause	Correction
1. Sharp or scarred edges on clamp. Metal deposits on underside of tail at buckle edge.	Loose or broken cutter blade / backing plate.	Make certain all fasteners are tight. Replace any broken or chipped blades. Cutter Blade and Backing each have a dual edge design and can be rotated to unused side one time before being replaced as a set.
2. Tail is broken at approximately 45°. Clamp material stretched or thinned at break.	Pull-up pressure set too high	Reduce pull-up pressure. Apply clamp and adjust if necessary.
3. Clamp tensions in a jerky manner.	Clamp not inserted properly.	Make sure clamp is straight and level when inserting.
	Band gripper pin loose	Tighten gripper pin set screw.
	Pull-up cylinder needs lubrication	Check filter / lubricator and add oil if necessary.
	Loose cutter blade on head	Check and tighten all hardware.
4. Clamp pulls but does not lock.	Clamp tail is too long and the end of stroke has been reached.	Reverse foot pedal and pull hose assembly back to expose clamp tail. Cut off excess clamp tail and resume.
	Center Punch head not connected after previous maintenance.	Connect cut-off cylinder with provided quick release pin assembly.
5. Clamp tail slips in band gripper lever.	Broken or worn teeth on gripper	Replace gripper.
	Pressure settings too high	Settings are a guide, it may be necessary to lower pressure settings.
	Gripper springs stretched out	Replace springs.
	Tripper plate stuck due to dirt or lack of lubrication	Check and clean/or re-lubricate the tripper plate.
6. Clamp tail folded and caught inside tool	Clamp tail catches as heel of foot pedal is depressed and cylinder is returned for next clamp cycle.	1) Re-cycle tool 2) Operate the tool to bring the piston to about half way. 3) To remove the clamp tail, reach under piston rod and locate band gripper lever. 4) Rotate lever toward clamp head and allow tail to fall from tool. If tail remains stuck, use pliers to grasp tail and carefully remove. <i>Never position fingers anywhere but on gripper lever!</i>
7. Tool doesn't cut-off clamp.	Loose or broken cutter blade	Tighten or replace cutter blade.
	CP Head disconnected	Connect CP Head assembly.
	Low pressure on incoming air supply	Check and adjust incoming air supply. Note: Minimum supply pressure is 70 PSI.
8. Tool takes excessive time for clamp pull-up.	Air leak from loose connection or worn parts	Remove tool cover and tighten loose connections and / or replace worn parts.
	Speed Control regulator set too low	Adjust to Blue setting per instructions.
9. Clamp tail cannot be inserted into tool.	Previous clamp tail has not yet been removed	Remove clamp tail from tool.
	Tripper plate may be broken or binding.	Remove, inspect, clean and lubricate or replace tripper plate.

# Preventative Maintenance



**BAND-IT**<sup>®</sup>  
A UNIT OF IDEX CORPORATION

# SM1700 Pneumatic Center Punch Tool

1. For best results and proper functioning of the SM1700 air tool, a filter / lubricator must be used on the air supply or in line within 30 feet of the air tool. The warranty is voided if a filter / lubricator is not used.
2. Before using air tool, check to see that the blade and backing plate on the CP head are fully tensioned. Loose bolts can easily cause breakage of blade and backing plate.
3. Clean gripper occasionally. Particles and dirt on the gripper lever can cause it to slip off the clamp tail. To remove gripper lever, loosen set screw in the head assembly from underneath the block and tap out pin.
4. The BAND-IT SM1700 Air Tool, although durable, does need periodic maintenance and repair. The frequency of significant repairs can be greatly reduced by simply following regular preventative maintenance such as maintaining tension on fasteners, proper lubrication and not “free cycling” the tool without tensioning clamps.

## Preventative Maintenance Schedule

Frequency	Component	Check
Daily	Tool and tool head	Check for and tighten all fasteners.
	Filter / Lubricator	Check for build-up of dirt, etc. Check for contaminated or discolored lubricant.
		Check for low lubricant. Refill with DTE 24 hydraulic oil. Set drip rate to 1 drop each 10-25 cycles.
Every 2,000 clamps	Gripper	Check for build-up of dirt, etc., in teeth. Remove and clean. Replace as necessary with new gripper kit.
Every 5,000 clamps	Cutter Blade and Backing Plate	Rotate both parts. If parts have been rotated once before, replace both as a kit.
Every 10,000 clamps	Tool Head	Return head to BAND-IT for service.
Every 6 Months	Cylinder	Check for build-up of dirt, contaminants on piston rod seals. Clean exterior with soap and warm water.
	Tripper Plate	Check for build-up of dirt, contaminants, etc. Clean and apply lubricant.
	Air Exhaust Mufflers	Check for build-up of dirt, contaminants, etc. Remove and clean with non-flammable degreaser.



**Center Punch  
Head Information**



**BAND-IT**<sup>®</sup>  
A UNIT OF IDEX CORPORATION

**SM1700  
Pneumatic  
Center Punch  
Tool**

*Periodically check  
mounting screws for  
tightness.*

**Important:** Do not actuate head unless installing a clamp. If any visible damage appears to head, discontinue use and return to BAND-IT<sup>®</sup>.

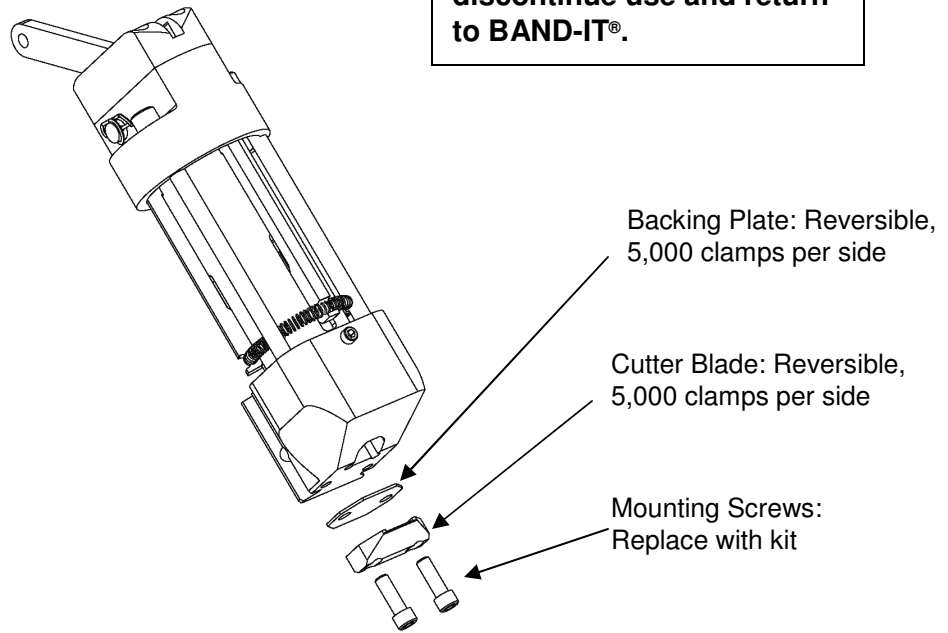

**REPLACEMENT PARTS LIST FOR THE HEAD**

Part Number	Qty	Description	
M17799	1	Cutter Blade Kit	Includes Blade, Backing plate, Mounting screws, and Instructions
M17098	1	Center Punch Head	Complete Head, Replacement

# Gripper Assembly



**BAND-IT**<sup>®</sup>  
A UNIT OF IDEX CORPORATION

# SM1700 Pneumatic Center Punch Tool

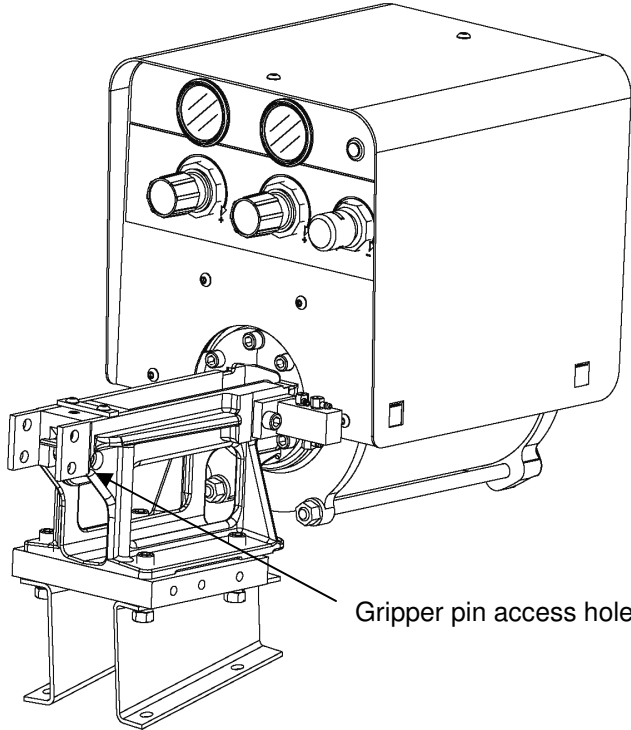

•To remove gripper and/or tripper plate:

1. Unhook the 2 gripper springs
2. Bring the piston fully forward
3. Loosen the gripper pin set screw
4. Tap the gripper pin out
5. To remove tripper plate, move the piston slightly back. Remove front plate, and slide free

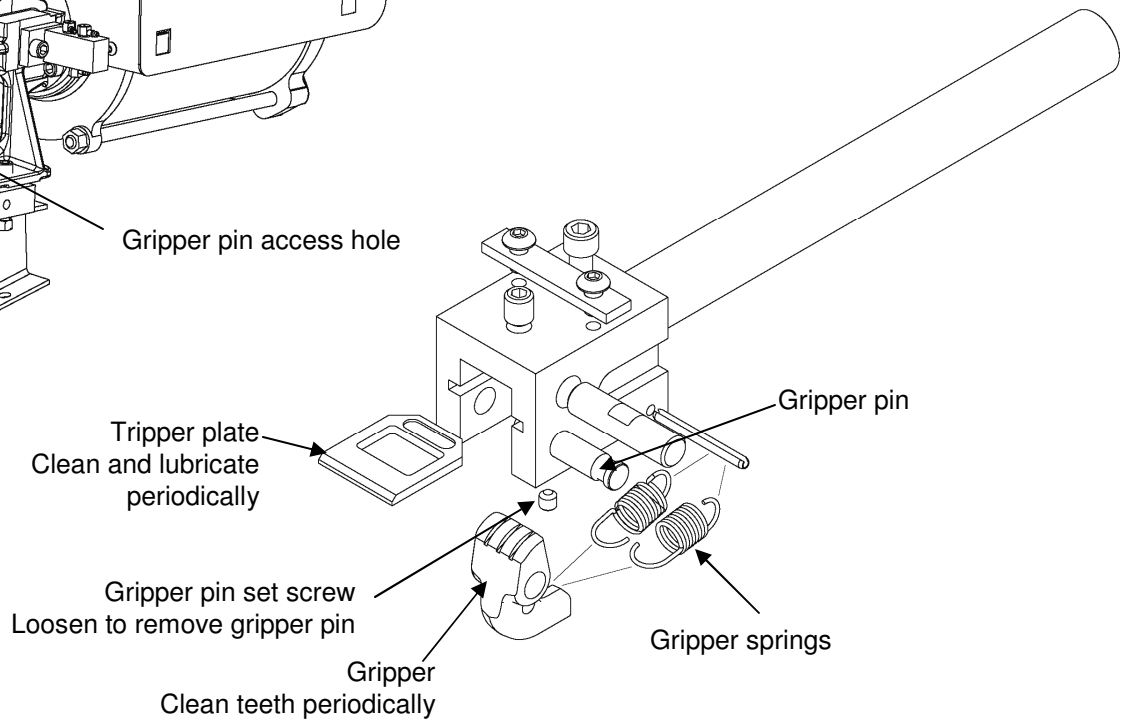

## REPLACEMENT PARTS LIST FOR THE GRIPPING SYSTEM

Part Number	Qty	Description	
S45087	1	Tripper plate	
S45199	1	Gripper Kit	Includes one Gripper and two Gripper springs

BAND-IT-IDEX, Inc.  
A Unit of IDEX Corporation

4799 Dahlia Street Denver, CO 80216-3070 USA

P: 1-800-525-0758 F: 1-800-624-3925

[www.BAND-IT-IDEX.com](http://www.BAND-IT-IDEX.com)

Document# SM1750 Rev C

© Copyright

BAND-IT-IDEX, Inc. 2008

All rights reserved

# Replacement Service Parts Identification



**BAND-IT**<sup>®</sup>  
A UNIT OF IDEX CORPORATION

# SM1700 Pneumatic Center Punch Tool

Production tools will experience wear of specific parts. Preventative Maintenance, including regular cleaning, lubrication and checking all fasteners for tension will reduce the replacement frequency of these parts.

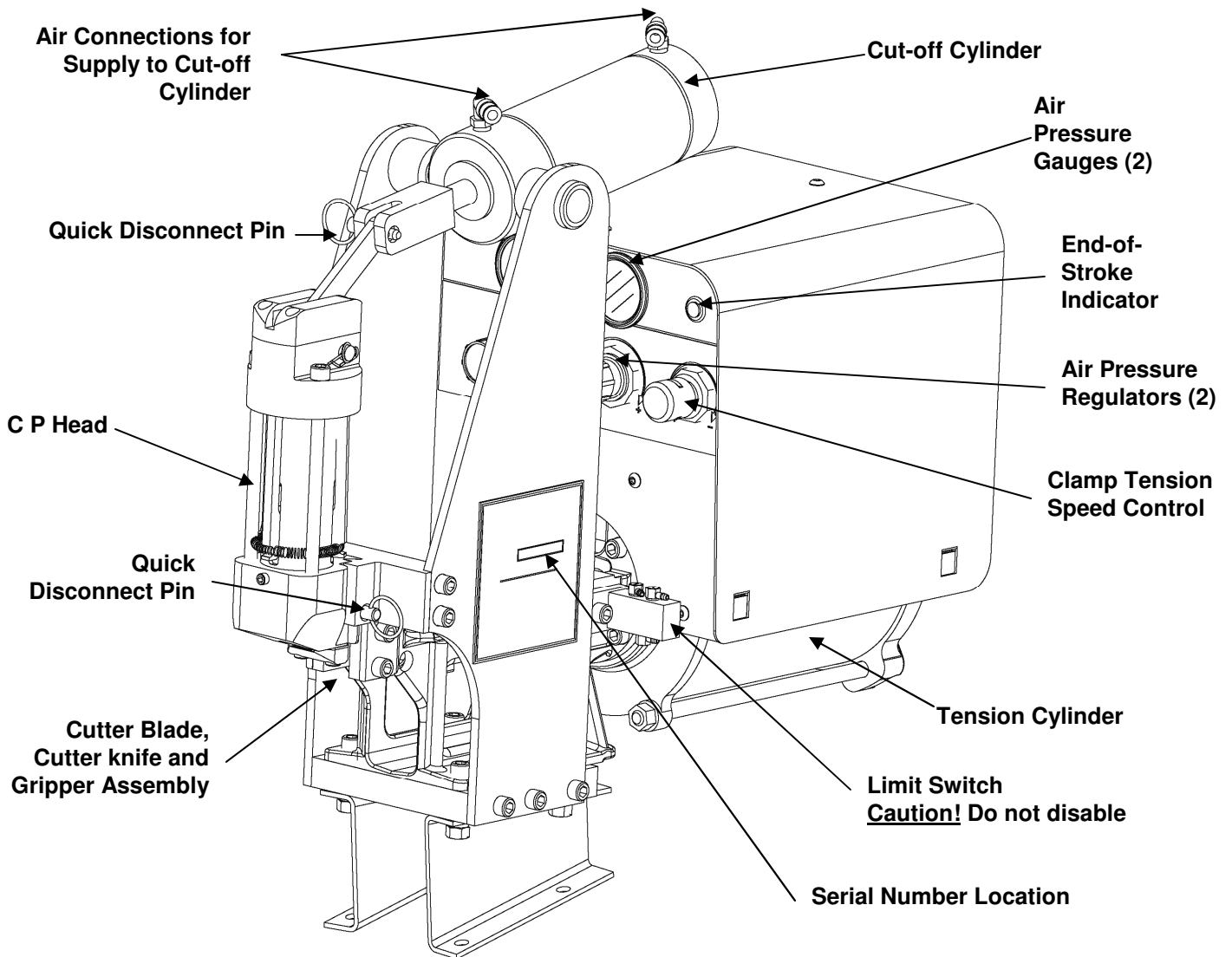

BAND-IT-IDEX, Inc.

A Unit of IDEX Corporation

4799 Dahlia Street Denver, CO 80216-3070 USA

P: 1-800-525-0758 F: 1-800-624-3925

[www.BAND-IT-IDEX.com](http://www.BAND-IT-IDEX.com)

Document# SM1750 Rev C

© Copyright

BAND-IT-IDEX, Inc. 2008

All rights reserved

# Air Connection Diagram



**BAND-IT**<sup>®</sup>  
A UNIT OF IDEX CORPORATION

# SM1700 Pneumatic Center Punch Tool

Internal tubes are made of bulk part numbers. See chart below. When ordering individual replacement tubes, specify tool part number (SM1700), tube part number, tube I.D. letter and tube length.

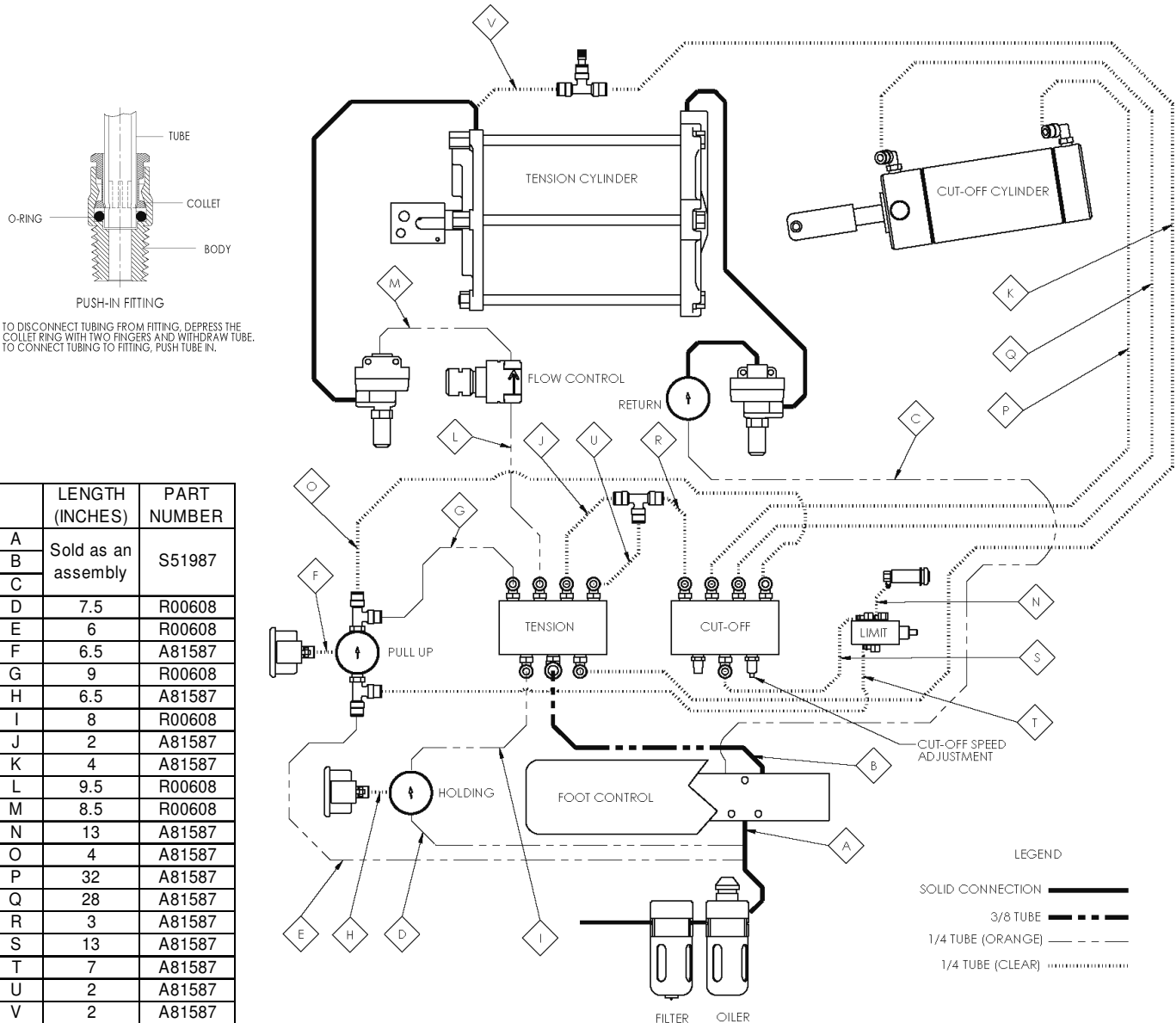

	LENGTH (INCHES)	PART NUMBER
A	Sold as an assembly	S51987
B		
C		
D	7.5	R00608
E	6	R00608
F	6.5	A81587
G	9	R00608
H	6.5	A81587
I	8	R00608
J	2	A81587
K	4	A81587
L	9.5	R00608
M	8.5	R00608
N	13	A81587
O	4	A81587
P	32	A81587
Q	28	A81587
R	3	A81587
S	13	A81587
T	7	A81587
U	2	A81587
V	2	A81587

BAND-IT-IDEX, Inc.  
A Unit of IDEX Corporation

4799 Dahlia Street Denver, CO 80216-3070 USA

P: 1-800-525-0758 F: 1-800-624-3925

[www.BAND-IT-IDEX.com](http://www.BAND-IT-IDEX.com)

Document# SM1750 Rev C

© Copyright

BAND-IT-IDEX, Inc. 2008

All rights reserved



## **Additional Factory Support and Tool Service:**

### **Factory Service is Available**

Users of the SM1700 should have years of dependable production if the preventative maintenance procedures are followed as outlined in this manual. In addition to available service parts, BAND-IT has additional factory service available. Service charges in addition to parts replacement charges will be invoiced if tool is not covered by our warranty. Please visit our website for our warranty information.

**[www.BAND-IT-IDEX.com/Warranty.html](http://www.BAND-IT-IDEX.com/Warranty.html)**

### **Tool Service Information**

1. If applicable, test and inspect tool to determine source of problem.
2. Totally dismantle tool and clean all parts.
3. Refinish external parts such as castings, cylinder, etc.
4. Inspect all parts for wear and damage. Replace as needed\*.
5. Replace all expendable parts\* such as gaskets, O-rings.
6. Reassemble, adjust, test, and inspect.
7. Clean exterior of tool.

\*Parts replaced are invoiced at current parts prices.