

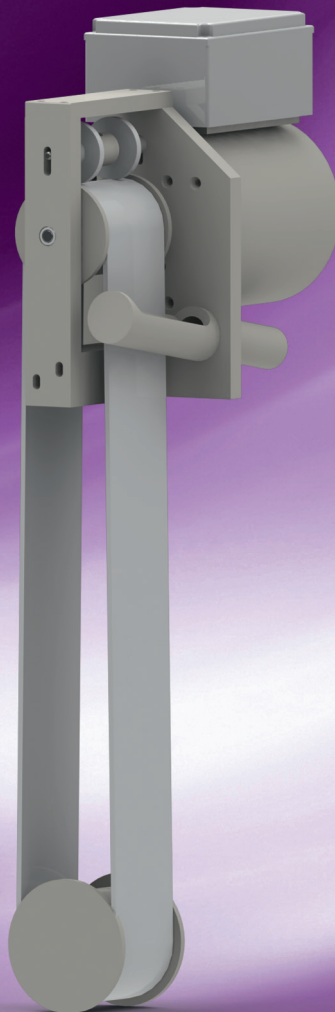

ARBO
THERMOPLASTIC
PUMPS
FILTERS



LI SERIE | FULLY PLASTIC

PG 10.0 OIL SKIMMERS



ARBO BELT OIL SKIMMERS

Your ARBO oil-skimmer does the dirty job!

- Light weight
- Easy to move around
- Low maintenance
- Controllable cost

The model LI-80 oil skimmer is a well-established and easy to install device for reducing pollution whilst at the same time recovering valuable materials, oils and fats from the surface of water and other liquids.

As all “wetted” parts are made of plastic, the use of this skimmer is not restricted to water only. Also alkaline liquids or acids can be treated successfully.

Floating oil adheres to an endless moving belt and is lifted vertically on the belt and skimmed of by a wiper tube for discharge to suitable storage vessels.

As the belt is only 80 mm. wide, the unit takes little space. The skimmer can therefore be mounted permanently on the bath and can clean continuously, also during production hours.

The belt is kept under tension by a free running drum without bearings.

As there are no mechanical parts in the liquid, breakdowns due to filthiness are quite impossible.

PRODUCT RANGE

TECHNICAL DETAILS

Easy to remove endless belt	80mm wide
Immersible depth below mounting surface	200-3000mm
Capacity at oil SAE10	0-4 l/h
Maximum operating temperature	70 °C

TECHNICAL DETAILS MOTORS

Standard	Maintenance free drive
Power	36 Watt
Duty	Continue duty: S1
Voltage	220-240 V/ 1 Ph/ 50/60Hz
Nominal current	0,36 A
Speed	2-10 min-1 via PCB with potmeter
Protection class	IP55 (IEC 34-5/ NEN-EN 60034-5)
Insulation class	“F” (ΔT=80 °C)
Maximale relative vochtigheid	< 95%

CONSTRUCTION

MATERIALS	ABBREVIATION	T MIN. °C	T MAX. °C
Skimmer parts of Polypropylene	PP	0	80
White skimmer belt for acids	W	0	70
Green skimmer belt for alkaline	G	0	70

ORDERING CODE (P.I.C.)

PRODUCT	TYPE	BELT LENGTH	MATERIAL WETTED PARTS	BELT
LI	80	200	PP	W
		400		G
		500		
		600		
		700		
		800		
		1000		
		1100		
		1200		
		1350		
		1500		
		1600		
		1700		
		2000		
		3000		

DETAILS OIL SKIMMERS

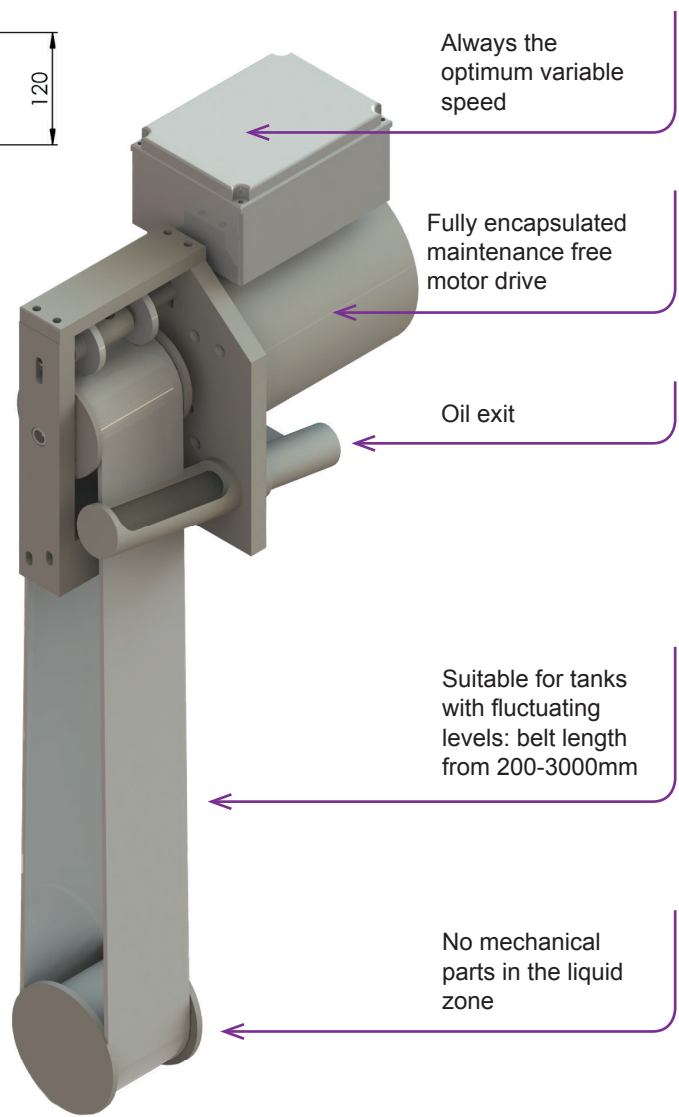
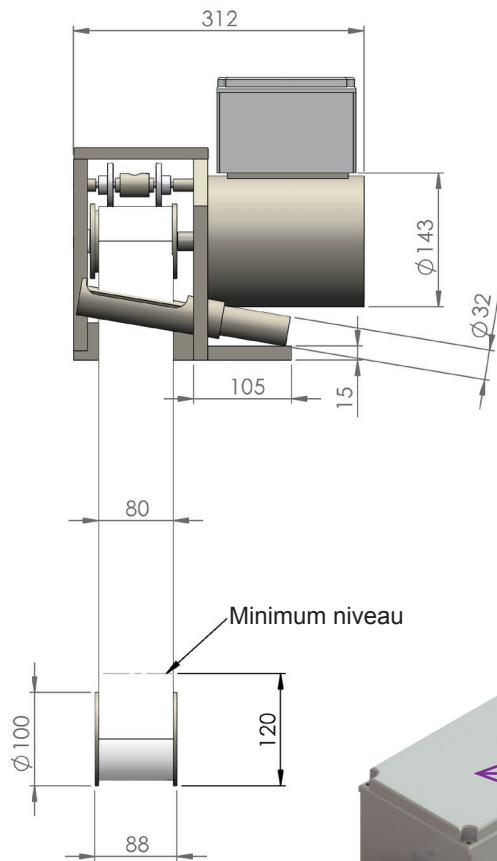
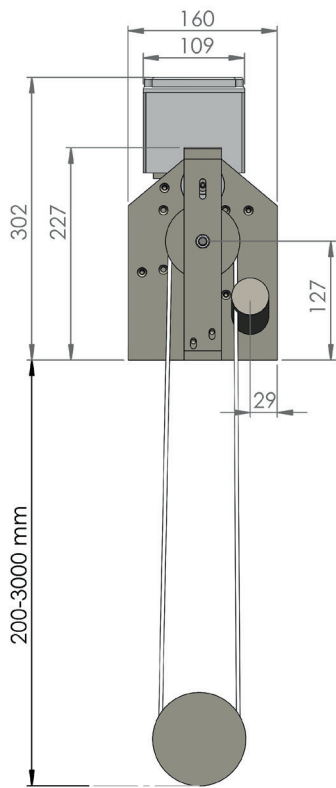



ARBO

THERMOPLASTIC
**PUMPS
FILTERS**

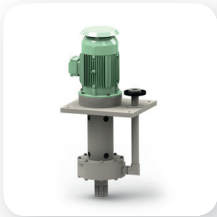

WHY ARBO PUMPS | FILTERS?

ARBO Pumps | Filters can be characterized by reliability, flexibility, quality and sustainability. Thanks to the smart design, the lower energy consumption and maintenance costs, your investment urn back time is very short time!

MARKETS

- Hot tub galvanising
- Anodising
- Plating
- Production of micro-electronic and semi-conductors
- Waste water treatment
- Fish farms
- Sea water aquaria
- Desalination plants
- Industrial and agricultural scrubbers
- etc.



**ARBO
POMPEN EN FILTERS B.V.**

Leemdijk 2
9422 CL SMILDE
THE NETHERLANDS

T : +31 (0) 592 430 310

E : info@arbo-pumps.com
I : www.arbo-pumps.com

DISTRIBUTED BY: